



HD 7+4 FRONT UNLOAD FORAGE BOX

OPERATOR'S MANUAL & PARTS BOOK



WARNING

READ AND UNDERSTAND THIS MANUAL BEFORE OPERATING THIS EQUIPMENT. UNSAFE OPERATION OR MAINTENANCE OF THIS EQUIPMENT CAN RESULT IN SERIOUS INJURY OR DEATH.

HSMFG0416

Manufactured By
H&S MANUFACTURING CO., INC.
P.O. BOX 768 • (715) 387-3414 FAX (715) 384-5463
MARSHFIELD, WISCONSIN 54449

CONTENTS

Warranty & Warranty Registration Card.....	1-2
Dealer Pre-Delivery & Delivery Checklist.....	3
Be Alert Symbol.....	5
Explanation of Safety Signs.....	6
Danger - Warning Signs.....	7-8
Warning - Owner Must Read and Understand.....	9
Warning - Emergency Stop.....	10
Bolt Torque Chart.....	11
Set-Up & Assembly.....	12
Transporting.....	13
Preparing for Operation.....	14
Operation.....	15-16
Adjustments.....	17-20
Service.....	21
Optional Features & Accessories.....	22
Lubrication Guide.....	23-24
Decal Location & Identification.....	25-26
Parts.....	27-49
Instructions For Ordering Parts.....	50
Parts Notes.....	51-52

WARRANTY

H&S WARRANTY

H&S Manufacturing Co., Inc. ("H&S") warrants this product to be free from defect in material and workmanship. Except as noted below, this warranty term is twelve (12) months from the date of delivery of the product to the original purchaser by an authorized H&S dealer. Under this warranty, H&S will repair or replace, at its option, any covered part which is found to be defective in material or workmanship during the applicable warranty term. In no case will the covered repair cost of a part or parts exceed the replacement cost of that part. Warranty service must be performed by H&S or a dealer authorized by H&S to sell and/or service the product involved, which will use only new or remanufactured parts or components furnished by H&S. This warranty includes approved parts and labor to fix the product but does not include, and the purchaser is responsible for, any service call and/or transportation of the product to and from the dealer's place of business, for any premium charged for overtime labor requested by the purchaser, and for any service work not directly related to any defect covered under this warranty. This warranty includes only those components of the product manufactured by H&S. Warranty for any component not manufactured by H&S including, but not limited to, engines, batteries, tires, rims, hydraulic motors, pumps, etc. are covered by the warranty, if any, provided separately by their respective manufacturers.

This warranty in all its parts, is extended solely to the original purchaser of the product, is terminated upon any subsequent transfer or sale from or by the original purchaser and extends no third party benefits or rights whatsoever.

The warranty term for any product used in any commercial, custom, for hire or rental application, is limited to six (6) months from the date of delivery of the product to the original purchaser or the first day of service, whichever comes first, by an authorized H&S dealer.

Floor and side panels utilized in H&S Manure Spreaders are warranted, to the original purchaser, to not wear through or delaminate for 10 years when used to spread normal agricultural manure. The frame, sides, end, floor and roof of forage boxes are warranted to not wear or rust through for 10 years when the forage box is used to transport freshly chopped forage. These specific warranties include only replacement of any defective panel part without any allowance for labor beyond the terms of the standard H&S 12 month warranty.

For commercial, custom for hire, or rental application, warranty is limited to 6 months from the date of delivery to the original purchaser, or the first day in service, whichever is earlier.

This warranty does not include: (1) Any product that has been altered or modified in ways not approved by H&S; (2) Depreciation or damage caused by normal wear, misuse, improper or insufficient maintenance, improper operation, accident or failure to follow the product Operator's Manual recommendations and product decal recommendations; (3) Normal maintenance parts and service; (4) Repairs made with parts other than those available from H&S or performed by anyone other than H&S or a dealer authorized by H&S to sell and/or service the product involved.

To secure warranty service the purchaser must report the product defect to a dealer authorized by H&S to sell and/or service the product involved within the applicable warranty term together with evidence of the warranty start date and make the product available to that dealer within a reasonable period of time.

HERE ARE NO WARRANTIES WHICH EXTEND BEYOND THE DESCRIPTION ON THE FACE OF THIS WARRANTY. H&S and the companies affiliated with it makes no warranties, representations, or promises, express or implied, as to the performance or freedom from defect of its products other than those set forth above and **NO IMPLIED WARRANTY OF MERCHANTABILITY, FITNESS OR FITNESS FOR A PARTICULAR PURPOSE IS MADE. IN NO EVENT WILL THE DEALER, H&S OR ANY COMPANY AFFILIATED WITH H&S BE LIABLE FOR INCIDENTAL OR CONSEQUENTIAL DAMAGES.** The **ONLY REMEDY** the purchaser has in connection with the breach of performance of any warranty on H&S products are those set forth above.

The selling dealer has no authority to make any representation or promise on behalf of H&S, or to modify the terms or limitations of this warranty in any way.

12/13

**FILL OUT
AND MAIL
IMMEDIATELY
TO MAKE
WARRANTY
EFFECTIVE**



WARRANTY REGISTRATION

Date of Purchase _____

Purchaser _____ Address _____

City _____ State _____ Zip _____

Product _____ Model# _____ Serial# _____

Dealer _____ Address _____

City _____ State _____ Zip _____

Signature of Original Buyer

MANUFACTURER'S STATEMENT

Your New H&S Product has been manufactured of the finest quality materials and components. The performance you get from your machine is largely dependent upon how well you read and understand this manual and apply this knowledge. There is a right and a wrong way to do everything. Please do not assume that you know how to operate and maintain your Machine before reading this manual carefully. Keep this manual available for ready reference.

IMPORTANT!

Tear on the dotted line, provide the information requested on the card. The H&S Warranty is valid **“only”** after this card is received and recorded at H&S Manufacturing Co., Inc. Mail at once. No postage is required in the U.S.A.



NO POSTAGE
NECESSARY
IF MAILED
IN THE
UNITED STATES

BUSINESS REPLY MAIL

FIRST CLASS MAIL Permit No.195 Marshfield, WI 54449

POSTAGE WILL BE PAID BY ADDRESSEE

H&S Manufacturing Co., Inc.
PO Box 768
Marshfield, WI 54449-9963



DEALER PRE-DELIVERY CHECK LIST

After the Forage Box has been completely set-up, check to be certain it is in correct running order before delivering to the customer. The following is a list of points to inspect. Check off each item as you have made the proper adjustments and found the item operating satisfactorily.

- Forage Box was not damaged in shipment. Check for dents and loose or missing parts. Report damage immediately to H&S Manufacturing Co., Inc.
- Forage Box has been correctly assembled according to the instructions in this manual.
- All shields and guards are in place and fastened.
- PTO shields turn freely.
- All grease fittings have been lubricated and gear boxes filled to proper level – See lubrication guide in this manual.
- All mechanisms are operating trouble free.
- All roller chains are at proper tension.
- Apron chains are adjusted properly.
- All bolts and fasteners are tight.
- 2 extra shear bolts are provided.
- All decals are in place and legible.

	Model Number
(Dealer's Name)	Serial Number
(Signature of Pre-Delivery Inspector)	(Inspection Date)

DEALER DELIVERY CHECK LIST

This check list that follows is an important reminder of valuable information that should be passed on to the customer at the time this Self-Unloading Forage Box is delivered. Check off each item as you explain it to the customer. This pre-delivery check list, when properly filled out and signed assures the customer that the pre-delivery service was satisfactorily performed.

- Explain to the customer that the pre-delivery inspection was made.
- Explain to the customer all the safety precautions they must exercise when operating this unit.
- Explain recommended loads for different types of materials.
- Explain to customer that regular lubrication is required for proper operation and long life of machine. Show customer the lubrication section of Owner's Manual.
- Give the customer Owner's Manual and make sure he reads and understands all operating and service instructions.
- Record Serial Number in this Manual.
- Have customer sign a completed "Warranty Registration," and mail it promptly.

Dealer's Name _____ By _____

Signature of Original Buyer _____ Date _____

Note: Warranty is not valid until warranty card is completed and returned to H&S Mfg. Co., Inc.

INTENTIONALLY LEFT BLANK

SAFETY INFORMATION



**BE
ALERT!**

**YOUR SAFETY
IS INVOLVED.**

THIS SYMBOL IS USED THROUGHOUT THIS BOOK WHENEVER YOUR PERSONAL SAFETY IS INVOLVED. TAKE TIME TO BE CAREFUL. REMEMBER: THE CAREFUL OPERATOR IS THE BEST OPERATOR. MOST ACCIDENTS ARE CAUSED BY HUMAN ERROR. CERTAIN PRECAUTIONS MUST BE OBSERVED TO PREVENT THE POSSIBILITY OF INJURY OR DAMAGE.

H&S MANUFACTURING CO. INC.

SAFETY INFORMATION

Keep signs in good condition. Immediately replace any missing or damaged signs.

RECOGNIZE SAFETY INFORMATION

This is the safety-alert symbol. When you see this symbol on your machine or in this manual, be alert to the potential for personal injury.

Follow recommended precautions and safe operating practices.



UNDERSTAND SIGNAL WORDS

A signal word - DANGER, WARNING, or CAUTION is used with the safety alert symbol. DANGER identifies the most serious hazards.

Safety signs with signal word DANGER or WARNING are typically near specific hazards.

General precautions are listed on CAUTION safety signs.



WARNING



CAUTION



CAUTION

FOLLOW SAFETY INSTRUCTIONS

Carefully read all safety messages in this manual, and all safety signs on your machine. Follow all recommended precautions and safe operating procedures.

OBSERVE MAXIMUM TRANSPORT SPEED

The maximum transport speed for this implement is 32 km/h (20 m.p.h.).

Some tractors are capable of operating at speeds that exceed the maximum transport speed of this implement. Regardless of the maximum speed capability of the tractor being used to tow this implement, do not exceed the implement's maximum transport speed.

Exceeding the implements maximum transport speed can result in:

- * Loss of control of the tractor/implement combinatio
- * Reduced or no ability to stop during brakin
- * Implement tire failur
- * Damage to the implement structure or its component

Use additional caution and reduce speed when towing under adverse surface conditions, when turning, and when on inclines.

Do not attempt transport if the fully loaded implement weighs more than 1.5 times the weight of the tractor.



SAFETY INFORMATION

⚠ DANGER



STAY CLEAR OF BEATER AND/OR CROSS CONVEYOR IF POWER SOURCE OR PTO IS RUNNING

FAILURE TO HEED THIS WARNING MAY RESULT IN PERSONAL INJURY OR DEATH

KEEP CLOTHING, YOURSELF AND OTHERS WELL CLEAR.

1494H

⚠ WARNING!



KEEP CHILDREN AWAY AT ALL TIMES!

2495

⚠ DANGER



MAINTAIN SAFE CLEARANCE FROM ELECTRIC POWER LINES AND AVOID CONTACT WITH ANY ELECTRICALLY CHARGED CONDUCTOR.

CONTACT WITH ELECTRIC POWER SOURCES CAN RESULT IN ELECTRICAL SHOCK OR ELECTROCUTION.

FAILURE TO HEED THIS WARNING MAY RESULT IN SERIOUS INJURY OR DEATH.

1494P

⚠ WARNING

HELP AVOID INJURY

- READ & UNDERSTAND THE OPERATORS MANUAL PROVIDED WITH THIS MACHINE. IF MISPLACED CALL H & S MANUFACTURING AT 715-387-3414 WITH MODEL AND NUMBER.
- UNDERSTAND ALL SAFETY WARNINGS AND FUNCTION OF CONTROLS.
- KEEP SAFETY DEVICES IN PLACE AND WORKING.
- KEEP YOURSELF AND OTHERS WELL CLEAR OF MOVING PARTS.
- DISCONNECT ALL POWER BEFORE SERVICING OR CLEANING THIS MACHINE.
- O NOT EXCEED 20 MPH

72203A

⚠ DANGER



ROTATING DRIVELINE CONTACT CAN CAUSE DEATH

KEEP AWAY!

DO NOT OPERATE WITHOUT—

- ALL DRIVELINE GUARDS, TRACTOR AND EQUIPMENT SHIELDS IN PLACE
- DRIVELINES SECURELY ATTACHED AT BOTH ENDS
- DRIVELINE GUARDS THAT TURN FREELY ON DRIVELINE

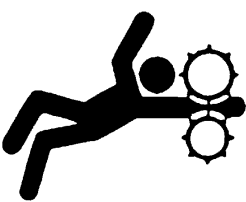

⚠ DANGER

NEVER ENTER FORGE BOX UNLESS THE FOLLOWING SAFETY PRECAUTIONS ARE FOLLOWED.

1494F

⚠ DANGER



ROTATING DRIVELINE CONTACT CAN CAUSE DEATH

5896B

SAFETY INFORMATION



WARNING

TO PREVENT SERIOUS INJURY OR DEATH
NEVER OPERATE THIS UNIT UNLESS
EMERGENCY STOP FUNCTIONS PROPERLY. 5896C

WARNING

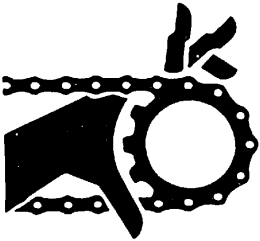

**DO NOT
REMOVE
SHIELDS**

**MOVING
PARTS
INSIDE**

1494K

WARNING

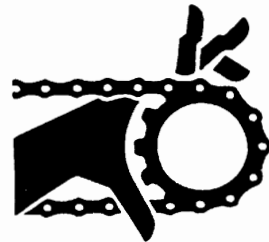

**DO NOT CLEAN
OR WORK ON THIS
MACHINE WITHOUT
FIRST DISENGAGING
POWER AND
SHUTTING OFF
TRACTOR ENGINE.**

1494J

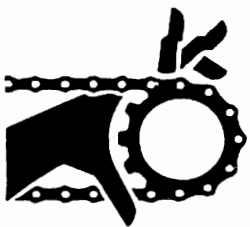

1494B

WARNING

**DO NOT
REMOVE
SHIELDS
MOVING PARTS
INSIDE**



1494E

WARNING

**DO NOT INSTALL
BOLSTER PLATES ONTO
BOX STRINGER
WITHOUT BLOCKING
BOX IF BOX IS
RAISED UP**

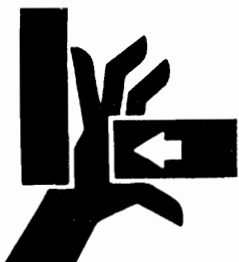

1494C

WARNING

**STAY CLEAR
MOVING PARTS
UNDER THIS
AREA**

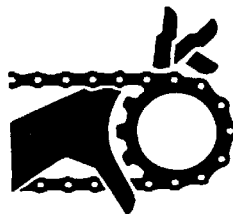

1494A

WARNING

**DO NOT OPERATE
THIS EQUIPMENT
IF THIS DECAL IS
EXPOSED.
REPLACE SAFETY
SHIELDS.**

TRACTOR:

This Operators Manual uses the term "Tractor" when identifying the power source.



TO PREVENT SERIOUS INJURY OR DEATH

BEFORE YOU ATTEMPT TO OPERATE THIS EQUIPMENT, READ AND STUDY THE FOLLOWING INFORMATION. IN ADDITION, MAKE SURE THAT EVERY INDIVIDUAL WHO OPERATES OR WORKS WITH THIS EQUIPMENT, WHETHER FAMILY MEMBER OR EMPLOYEE, IS FAMILIAR WITH THESE SAFETY PRECAUTIONS. KNOW HOW TO STOP UNLOADING MECHANISM BEFORE STARTING IT.

EMERGENCY STOP DOES NOT STOP FORAGE BOX WHEN BEING OPERATED AS A REAR UNLOAD.

If the machine becomes clogged, disengage the PTO or tractor hydraulics. Stop the tractor engine and allow all mechanisms to stop before cleaning or working on the machine.

DO NOT attempt to perform maintenance or repair with tractor running and PTO or tractor hydraulics hooked up.

DO NOT step up on machine at any time.

NEVER manually feed material into the beaters.

DO NOT allow minors to operate or be near the machine.

DO NOT ALLOW PERSONNEL OTHER THAN THE QUALIFIED OPERATOR NEAR THE MACHINE.

BEFORE starting tractor, be sure PTO shields turn freely and PTO is securely locked to tractor.

DO NOT clean, adjust, or lubricate the machine when any part is in operation.

CHECK frequently to be assured that the emergency stop mechanism is in proper operating condition. **KEEP** hands, feet, and clothing away from beaters when they are revolving .

LOOSE or floppy clothing should not be worn by the operator.

BE SURE the machine is clear of people, tools, and other objects before engaging PTO or tractor hydraulics.

STAY CLEAR of hydraulic lines and fittings. They may be under extreme pressure or heat.

DO NOT step over power take off shaft. Stay clear of PTO at all times.

NEVER start forage box until all guards and safety shields are secured in place.

NEVER put hand in cross conveyor outlet openings while tractor is running.

CAUTION – Beware of low electrical wires.

NEVER hook up 1000 RPM tractor to the forage box.

STAY CLEAR of rear of forage box at all times.

H&S Mfg. Co. always takes the operator and his safety into consideration and guards exposed moving parts for his protection. However, some areas cannot be guarded or shielded in order to assure proper operation. In addition, the operators manual and decals on the machine itself warn you of further danger and should be read and observed closely.

Study The Above Safety Rules
ATTENTION - BE ALERT - YOUR SAFETY IS INVOLVED

SAFETY INFORMATION



WARNING

**TO PREVENT SERIOUS INJURY OF DEATH NEVER OPERATE THIS UNIT
UNLESS EMERGENCY STOP FUNCTIONS PROPERLY**

EMERGENCY STOP

1. In case of an emergency, pushing either the stop panel rearward (A), or pulling the trip cables (B) will stop cross conveyor, beaters, and main apron.
2. Activating emergency stop only stops box functions. The PTO shaft will continue to rotate.
3. Keep excessive slack out of trip cables.
4. Trip emergency stop occasionally, and when starting the unit after periods of storage to insure proper function.
5. To reset, move lever (C) clock wise to engage position.

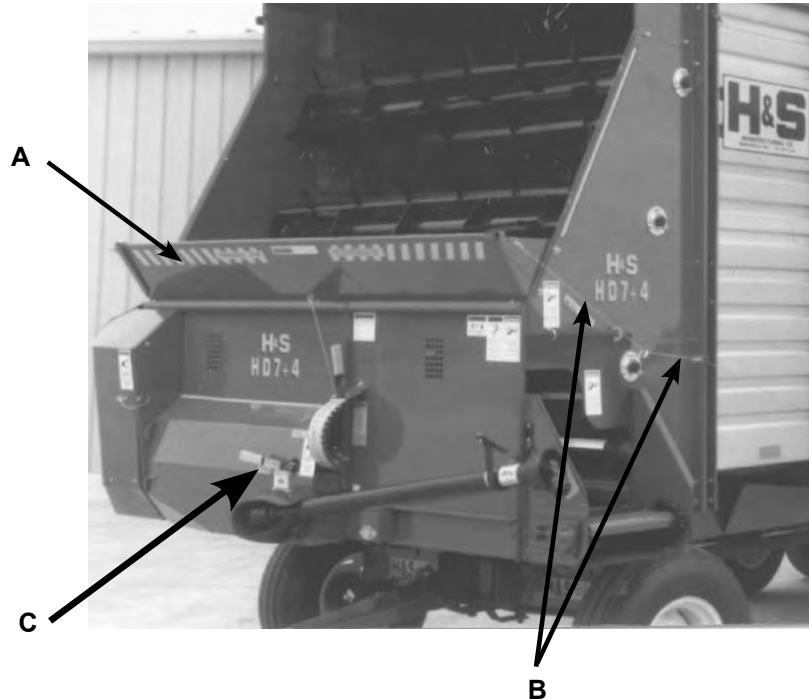

CAP SCREW TORQUE VALUES

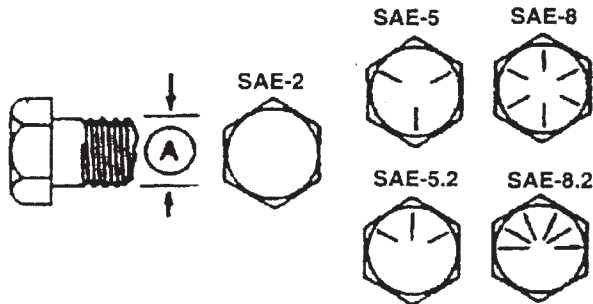

Inch Cap Screw Head Markings

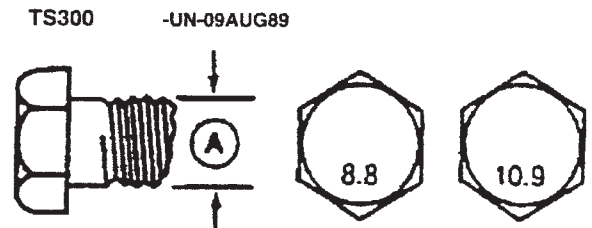

Metric Cap Screw Head Markings

INCH CAP SCREW TORQUE VALUES

METRIC CAP SCREW TORQUE VALUES

Bolt Diameter Wrench (A) Size	Cap Screw Grade							
	SAE 2		SAE 5		SAE 8			
N-m	lb.-ft	N-m	lb.-ft	N-m	lb.-ft	N-m	lb.-ft	
1/4"	7	(5)	11	(8)	16	(12)		
5/16"	14	(10)	23	(17)	33	(24)		
3/8"	24	(18)	41	(30)	54	(40)		
7/16"	41	(30)	68	(50)	95	(70)		
1/2"	61	(45)	102	(75)	142	(105)		
9/16"	88	(65)	142	(105)	203	(150)		
5/8"	122	(90)	197	(145)	278	(205)		
3/4"	217	(160)	353	(260)	495	(365)		
7/8"	224	(165)	563	(415)	800	(590)		
1"	332	(245)	848	(625)	1193	(880)		
1-1/4"	665	(490)	1492	(1100)	2393	(1765)		

Bolt Diameter Wrench (A) Size	Markings on Cap Screw Heads							
	8.8		10.9		8.8		10.9	
N-m	lb.-ft	N-m	lb.-ft	N-m	lb.-ft	N-m	lb.-ft	
5 mm	6	(4.5)	9	(6.5)				
6 mm	10	(7.5)	15	(11)				
8 mm	25	(18)	35	(26)				
10 mm	50	(37)	75	(55)				
12 mm	85	(63)	130	(97)				
16 mm	215	(159)	315	(232)				
20 mm	435	(321)	620	(457)				
24 mm	750	(553)	1070	(789)				
30 mm	1495	(1103)	2130	(1571)				



CAUTION: Use only metric tools on metric hardware. Other tools may not fit properly. They may slip and cause injury.

DO NOT use these values if a different torque value tightening procedure is listed for a specific application. Torque values listed are for general use only. Check tightness of cap screws periodically.

Shear bolts are designed to fail under predetermined loads. Always replace shear bolts with identical grade. Fasteners should be replaced with the same or higher grade. If higher grade fasteners are used, these should only be tightened to the strength of the original.

Make sure fastener threads are clean and you properly start thread engagement. This will prevent them from failing when tightening.

Tighten plastic insert or crimped steel-type lock nuts to approximately 50 percent of amount shown in chart. Tighten toothed or serrated-type lock nuts to full torque value.

SET-UP & ASSEMBLY



WARNING: Some photographs used in the following pages show guards or shields removed for clarification. Never operate machine until these guards or shields are in proper operating position.

NOTE: Determine right or left side of the forage box by viewing it from the rear. If instructions or parts lists call for hardened bolts, refer to the Cap Screw Torque Value page to identify.

1. Check the Forage Box for proper assembly and adjustment. Make sure that all bolts are tightened.
2. Properly lubricate the Forage Box before operating. Refer to Lubrication Section of this Operator's Manual for locations.
3. **GEARBOXES:**
Main Apron Drive Gearbox; Keep the main apron gearbox filled to the oil level plug in cover of gearbox using 85W140 lubricant.

Beater Drive Gearbox; Keep the beater drive gearbox filled to the center of the shafts. Use 80W90 lubricant.
4. Check all lights to make sure that they are functioning properly.

TRANSPORTING

TRANSPORT LIGHTING & REFLECTORS

WHEN TRANSPORTING ON THE HIGHWAY OR ROADS, PLACE SMV SIGN IN SOCKET PROVIDED AND REGULARLY CLEAN THE REFLECTIVE TAPE AT THE REAR OF THE FORAGE BOX.

NOTE: Obey all state and local laws, concerning towed equipment, on public roads.

TOWING ON HIGHWAY

To view beyond the back of the Forage Box when transporting the unit on a public highway, consider obtaining and installing a rear view mirror on your tractor with a wide load mounting bracket.

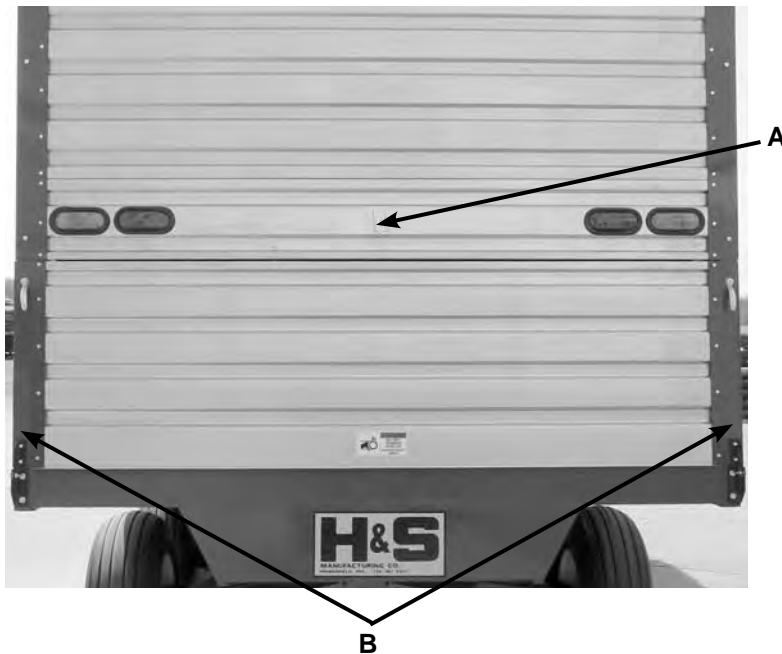

Transport lighting is standard on all models. The lighting system is to be connected to the 7 pin power receptacle (per SAEJ560B) on your tractor. If your tractor is not equipped with the proper receptacle, see your tractor dealer for details. Red reflective safety decals are on the rear of the box for safety.

T [~ } ç * Û [& ^ ç | Û T X Ò { à | { Æ D
Û ^ à Û ^ - ^ & ç ^ Á ç ^ Æ D

Mounting Socket for SMV Emblem (A)

Red Reflective Tape (B)

PREPARING FOR OPERATION

Check over entire unit carefully before first operation. Tighten bolts, set screws, and chains which may have come loose in handling. Lubricate as explained in the Lubrication Guide. Successful operation will be achieved by periodic adjustments and experience of the operator. Make sure to read and understand all adjustments.

TRACTION CONNECTIONS

PTO Drive

Attach the Forage Box PTO to the tractor PTO shaft locking it into position. Maintain correct distance between the tractor drawbar hitch, tractor PTO and the universal joint at front of unit. This is necessary to prevent overextending the universal joint shaft.

1. Maintain a straight alignment between the Forage Box and the tractor.
2. Maintain a distance of 6"- 12" between the top of the tractor drawbar and the center of the tractor PTO. An 8" distance is standard.

After the correct distance is obtained, depress the locking collar against the spring tension, and slide the yoke onto the tractor PTO shaft. Release the locking collar and move the yoke ahead or back until the lock engages into the groove on the shaft.

NOTE: Do NOT attempt to use a hammer to help in attaching the PTO drive connection.

The tractor drawbar should be adjusted in relation to the tractor PTO shaft as follows:

1. Hitch point of drawbar 14 inches behind tractor PTO shaft.
2. Hitch point of drawbar at least 8 inches, but not more than 14 inches below PTO shaft.
3. Hitch point of drawbar at least 13 inches, but not more than 22 inches above ground level.
4. When unloading, keep the hitch point of the drawbar and PTO shaft in a straight line to the Forage Box. If the PTO is at an angle, it will result in a pounding noise and damage to U joints and the safety clutch.

IMPORANT! DO NOT operate unless 2" minimum extension is maintained.

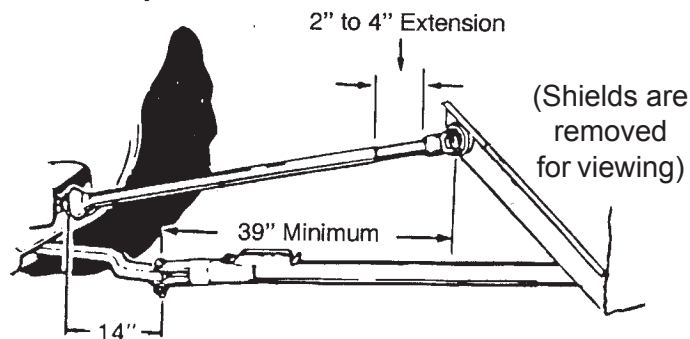

The telescoping PTO drive is designed to rotate freely inside the drive shield tubes. Run the unloading mechanism for several minutes. This will serve as a break-in and as a check that all parts are assembled and lubricated properly.

After you have run the Forage Box for several minutes, check the main apron chains again for proper adjustment, as paint may initially come off the apron chains and chains may loosen. The main apron chains must be taken up evenly before you use the forage box. Check again after the first few loads. The main aprons should be at proper tension at all times. See [Adjustment Section](#) for details.

The Power Take Off Shaft from tractor to box should not be connected for road travel or field operation. Damage may result to the PTO Shaft. A convenient hanger is provided to hold PTO shaft during the time it is not being used to unload.



OPERATION

GENERAL INFORMATION

Check entire Forage Box carefully before first operation. Tighten bolts and set screws that might have come loose in transporting. Lubricate if needed as explained in the Lubrication Chapter in this manual.

EMERGENCY SHUTDOWN

In case of an emergency, pushing the emergency stop panel, emergency stop bar, or pulling the safety cable will stop cross conveyor, beaters, and main aprons. PTO will continue to rotate. If the Forage Box is plugged with material or a foreign object becomes lodged in the discharge area, disengage the PTO. Stop the tractor engine, remove ignition key, and allow all mechanisms to stop before cleaning or working on the machine. Trip emergency stop occasionally to insure proper function.



Emergency Stop Panel

Emergency Stop Cable



CONTROLS & SAFETY EQUIPMENT

Forage Boxes are provided with several features for operator safety and convenience.

Guards & Shields

Whenever possible and without affecting the operation of the Forage Box guards, shields and/or hinged shields have been used on this equipment to protect potentially hazardous areas. In many places, decals are also provided to warn of potential dangers as well as to display special operational procedures.

PTO Shields

Care must be taken to keep male and female driving elements well lubricated and free sliding. The shield surface must be kept dry, as dirt accumulation on them will quickly cause these units to bind and not rotate. If, at any time the shields do not turn freely, they should be checked to determine the cause, and repaired or cleared. **DO NOT STEP OVER PTO SHAFT. STAY CLEAR OF ROTATING PTO AT ALL TIMES. DO NOT OVEREXTEND PTO.**

A spring loaded plastic guard which protects the operator from accidentally being exposed to the beater and apron at the discharge opening during operation of the Forage Box. Keep this guard in proper position at all times when operating the forage box.

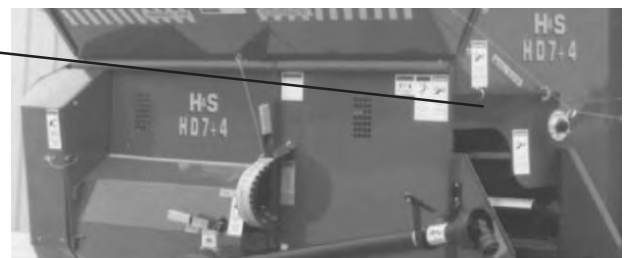

OPERATION

OPERATION OF FRONT UNLOAD FORAGE BOX

1. Park the Forage Box on level ground whenever possible during unloading. Lock tractor parking brake
2. Connect the PTO to a tractor with a 540 PTO ONLY, locking securely in place as stated in the PREPARING FOR OPERATION SECTION.
3. Engage PTO

NOTE: Do NOT exceed the rated 540 RPM operating speed of the Forage Box

4. To engage cross conveyor INTERMITTENTLY, rotate clutch lever (A) clockwise and hold with hand pressure. If hand pressure is removed, the cross conveyor will stop.

5. To engage the cross conveyor CONTINUOUSLY, rotate clutch lever clockwise until it locks in the engage position. Cross conveyor speed is controlled by the tractor RPM only.

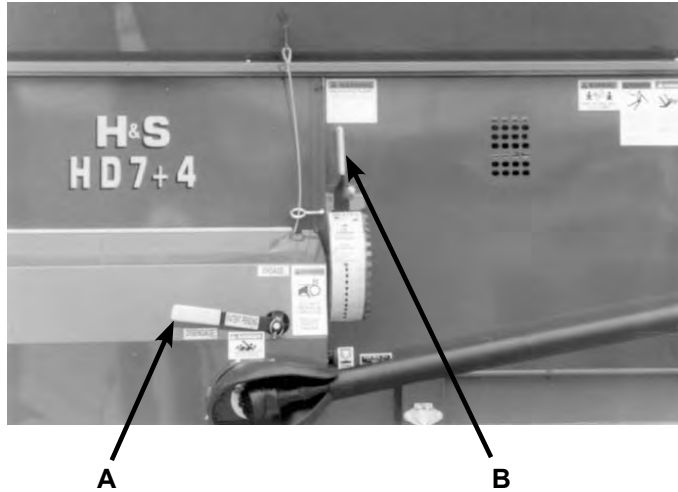

6. Quickly engaging/disengage beater lever will allow beaters to clear material a little at a time to avoid exceeding blower capacity. This single lever controls both beater engage/disengage and the speed of the main feeder aprons. **CAUTION:** DO NOT ENGAGE BEATERS OR MAIN APRONS WHEN CROSS CONVEYOR IS FULL OF MATERIAL OR DAMAGE TO FORAGE BOX WILL RESULT.

7. When beaters are clear of material, move control lever to apron speed position. Variable speed drive offers you a number of unloading speeds to choose from. Rotating the lever downward starts and gradually increases main apron speed. With experience and depending on the type of forage, you will be able to select a speed which will match your blower capacity. Unloading speed may also be varied by increasing or decreasing engine speed of tractor.

8. If it is necessary to trip the stop mechanism and disengage the Forage Box drive before the box empty, restart unloading by engaging clutch lever.

9. Clean out position is for cleaning out the forage box at the end of the load.

10. When the Forage Box is empty, move the control lever to disengage position. AFTER UNLOADING, ALWAYS RETURN THE CONTROL LEVER TO THE NEUTRAL POSITION **WITH PTO RUNNING**.

11. Disconnect the PTO and place it in the convenient holder for field and road use.

ADJUSTMENTS

MAIN APRON

Main feeder apron adjustment bolts are located behind the convenient access door located in the bottom portion of rear tailgate .Remove handle nuts (A) to open access door and swing door downward.

All apron chains must be taken up evenly before you use the forage box .Check again after the first few loads .The Main Feeder Aprons should be at proper tension at all times .Tighten the full threaded bolts (B) to adjust aprons .Aprons are properly adjusted when two Cross Slats, or about three feet of chain lift off the Chain Return Slides from the rear of the box .Maintain this tension when operating the box.

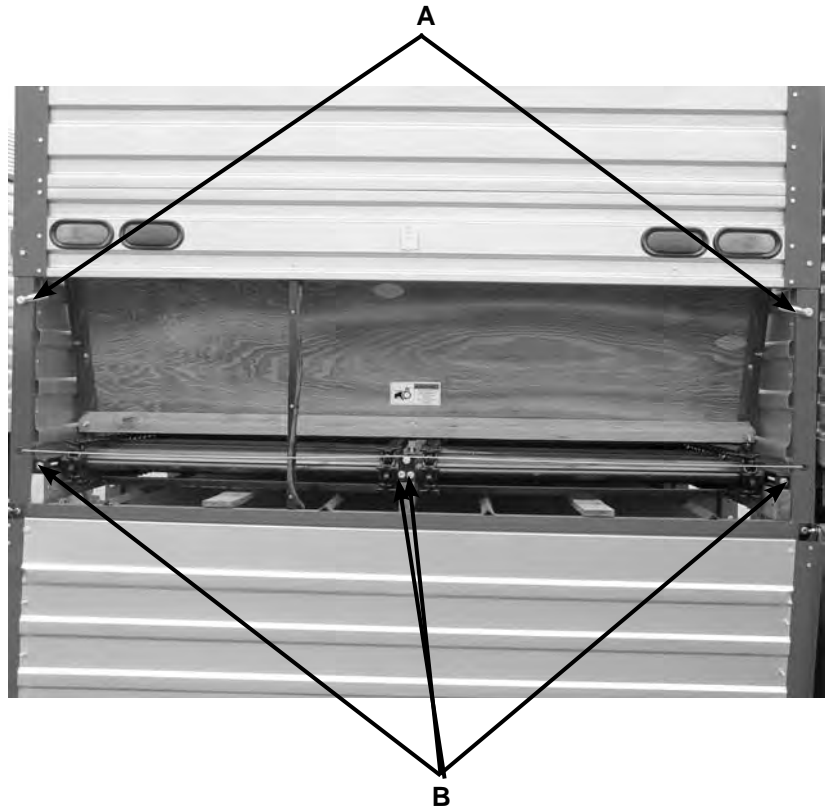
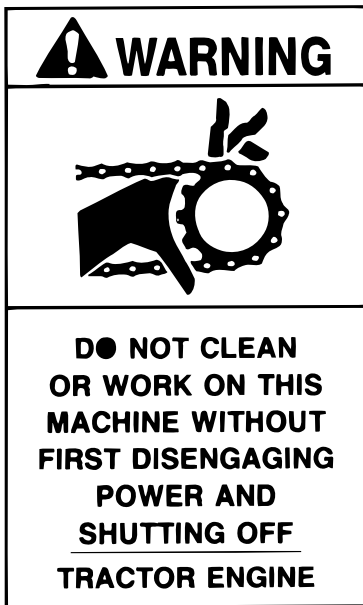

ADJUSTMENTS

CROSS CONVEYOR

Proper tension should be maintained on cross conveyor chain when operating box .To adjust cross conveyor, loosen the jam nuts (A) on tightener bolts (B) . Move adjusting nuts (C) on tightener bolts until proper tension on chain is reached .The chain is properly adjusted when the center slats clear the bottom return pan by about 1/16 of an inch .Adjust both sides equally .Lock in place with jam nuts.

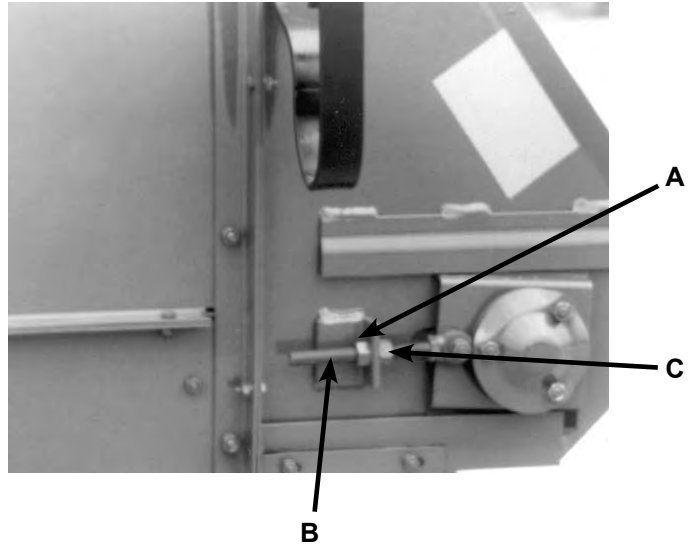

SHEAR BOLT

The cross conveyor is protected by two shear bolts, located in the drive sprocket and shear hub assembly, located at the right hand end of cross conveyor. Two spare shear bolts are provided. Always determine the cause of failure and eliminate the cause before installing new shear bolts. Use only H&S shear bolts when replacing.

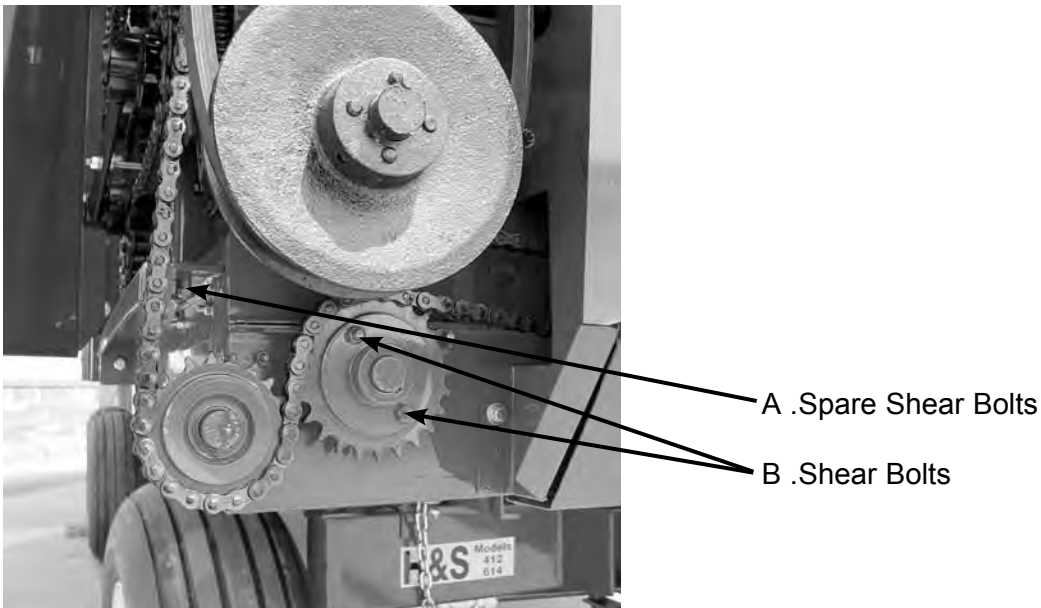

ADJUSTMENTS

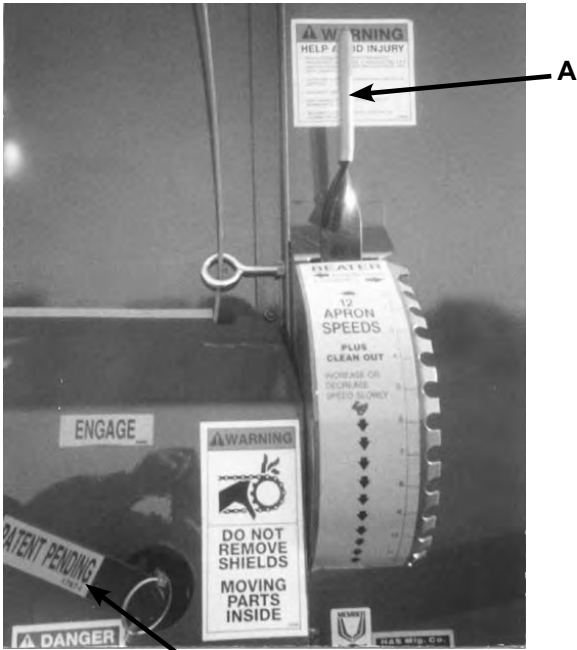

BEATER ENGAGE/APRON SPEED CONTROL LEVER

This single lever (A) controls both beater engage/disengage and the speed of the main feeder aprons. **CAUTION:** DO NOT ENGAGE BEATERS OR MAIN APRONS WHEN CROSS CONVEYOR IS FULL OF MATERIAL OR DAMAGE TO FORAGE BOX WILL RESULT. Prior to engaging beaters and main aprons, intermittently rotate emergency stop lever (B) to the engage position to clear cross conveyor of all material. When beater control lever is engaged, the beaters and main aprons will start at the same time. AFTER UNLOADING, ALWAYS RETURN THE CONTROL LEVER TO THE NEUTRAL POSITION WITH PTO RUNNING.

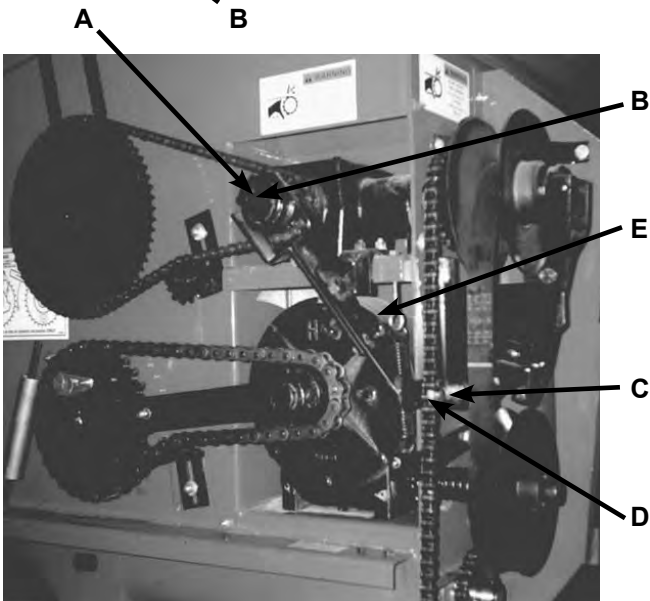

BEATER CLUTCH ADJUSTMENT Check beater clutch periodically to insure beaters are being completely engaged or disengaged. Beater engage/disengage clutch is properly adjusted when there is 1/8 inch of clearance between clutch jaw (A) and engaging pin (B), when control lever is in the disengage position. Basic adjustment can be made by positioning adjusting nut (C) 2-7/8" from end of control rod. Place control arm (D) tight against nut. Adjust mounting bracket (E) in slotted holes on unit until 1/8" clearance is reached. Fine adjustment is made by adjusting nut (C) on control rod.

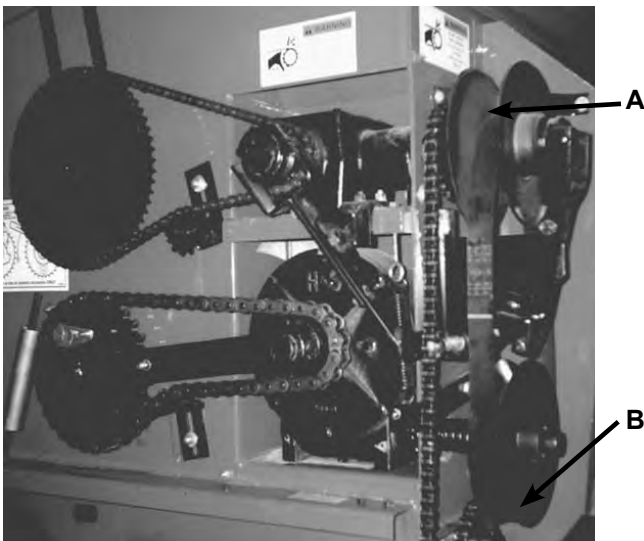

VARIABLE SPEED DRIVE BELT

After extended use of forage box, it may become necessary to adjust or replace variable speed drive belt.

BELT REPLACEMENT

If it becomes necessary to replace the variable speed drive belt, follow the steps listed below to remove worn belt:

1. Place control lever in beater disengage position.
2. Open upper sheaves (A) so belt rests on drive pins.
3. Remove belt from lower sheaves (B) first and then upper sheaves.

Reverse the above steps when installing new belt.

ADJUSTMENTS

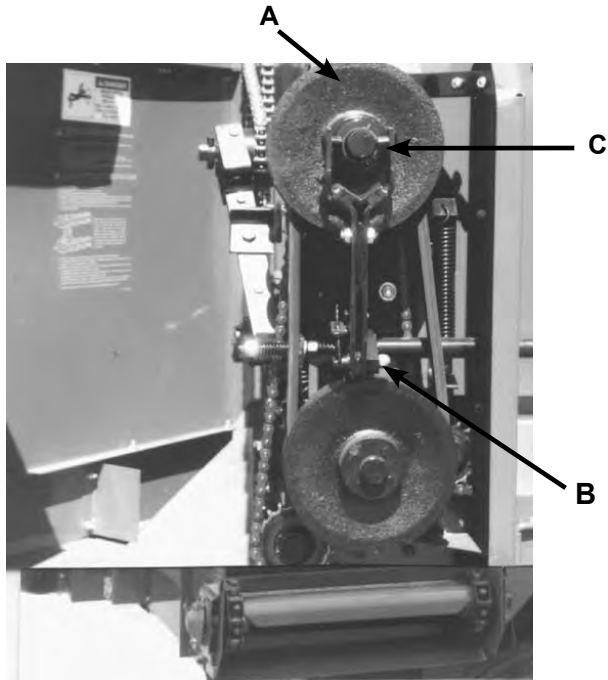

VARIABLE SPEED ADJUSTMENT

You should rarely have to adjust the variable speed drive belt. If, however, it becomes necessary to adjust the belt, follow the steps listed below:

1. Remove belt as previously instructed.
2. Move control lever to the highest apron speed position.
3. Check upper sheaves (A), if base of sheaves are not tight together, it is necessary to adjust.
4. Remove bolt from control rod (B).
5. Slide sheaves tight together, being sure control yoke (C) is tight against thrust bearing and sheaves.
6. Adjust control rod (B) so hole in control yoke and rod align, then one additional turn.
7. Replace bolt. Allow sufficient play when tightening, so control rod pivots.
8. Place control lever in beater disengage position and replace the belt.

SERVICE

ENTERING FORAGE BOX

Front Unload

If you plan to manually unload the Forage Box utilizing cross conveyor, the following two-man procedure must be followed. **NEVER ATTEMPT THIS PROCEDURE ALONE. THE PERSON OUTSIDE OF FORAGE BOX OPERATING CONTROLS MUST NOT LEAVE CONTROLS.**

1. Place control lever in beater disengage position.
2. Disengage tractor PTO, shut off tractor, and remove the ignition key.
3. Disengage tractor hydraulics, shut off tractor, and remove the ignition key.
4. Remove variable speed drive belt. This will prevent main aprons from moving.
5. Remove connector link from beater drive roller chain and remove chain from sprockets.
CAUTION: BEATERS ARE NOW FREE TO ROTATE
6. Using a short piece of chain with hooks, secure top beater to center beater. See picture below.
7. Wrap chain around bar of third beater and top bar of second beater. Secure chain together as tight as possible to eliminate beaters from rotating in either direction. Keep excess chain out of cross conveyor chamber. **NOTE:** Hook chain properly and securely to prevent unhooking during this procedure.
8. Using extreme caution, the first person may now climb over beaters.
9. When the first person is clear of beaters, second person may start tractor and engage PTO to operate cross conveyor.
10. Before first person attempts to leave forage box, second person must disengage tractor PTO, shut off tractor, and remove the ignition key.
11. When forage box is clear of people, remove safety chain from beaters, re-install drive belt and beater drive chain. Adjust tightener on roller chain.

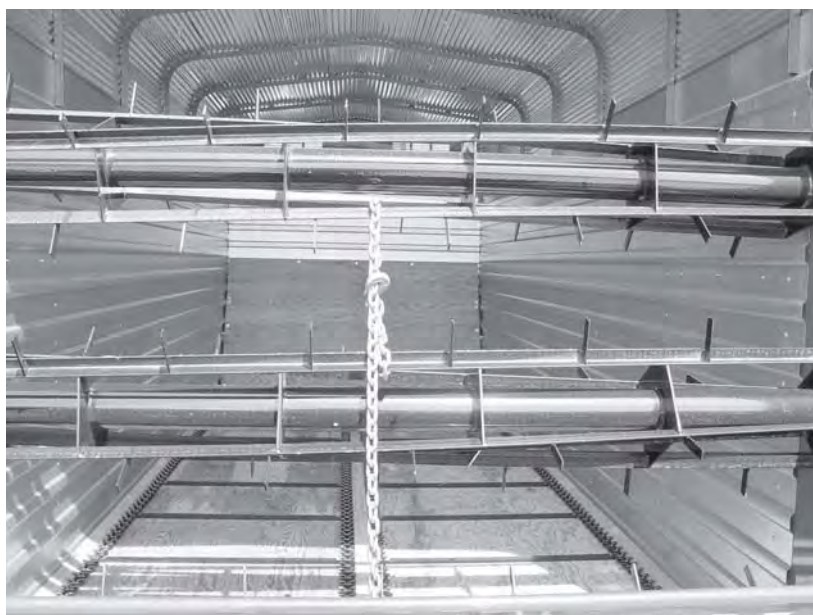

OPTIONS

12" & 24" FOLD DOWN EXTENSION

Extension folds down for easy access to blower and folds up for road and field travel



FOLDED DOWN



FOLDED UP

HYDRAULIC DRIVE

Hydraulic drive unit easily mounts and dismounts from unit

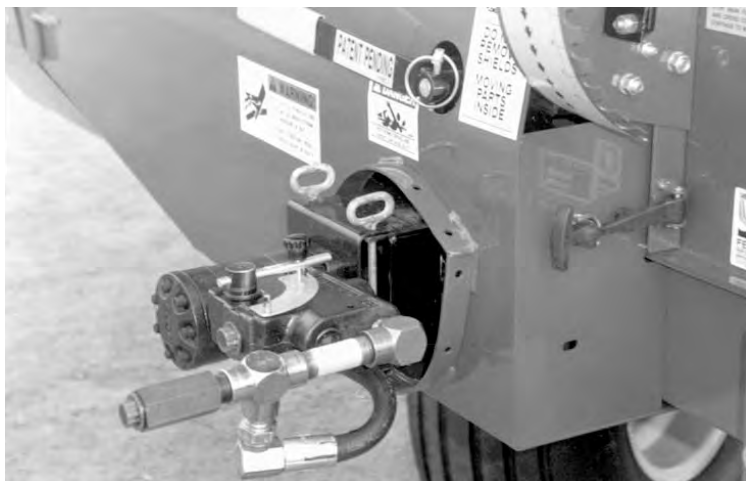

LUBRICATION

GENERAL INFORMATION

IMPORTANT: *Catch and dispose of fluid per local waste disposal regulations whenever service is performed on hydraulic components, valves, cylinders, hoses, etc.*

GREASING

There are numerous grease fittings on the Forage Box. Become familiar with all lubrication points and establish a routine to ensure complete lubrication of the Forage Box. Lubricated properly and often, (every 10 hours) with a high-quality grease, will prolong the life of the forage box. Replace any missing or plugged grease fittings. Wipe dirt from the fittings before greasing to prevent the dirt from being forced into the bearing or pivot. Grease should come out around the shaft on sleeve type bearings. On the sealed ball bearings, grease should be added slowly until a slight bead forms at the seal indicating the correct amount of lubricant. To minimize dirt build-up, avoid excessive greasing. After greasing, wipe off the excess grease from around the outside of the bearings to prevent the accumulation of chaff and grit.

GEARBOXES

Main Apron Drive Gearbox; Keep the main apron gearbox filled to the oil level plug in cover of gearbox using 85W140 lubricant.

Beater Drive Gearbox; Keep the beater drive gearbox filled to the center of the shafts. Use 80W90 lubricant.

DRIVE CHAINS

Lubricate the drive chains with a light machine oil. Keep chains aligned with sprockets, this lengthen the life of the sprockets and chain. Lubricate chains often.

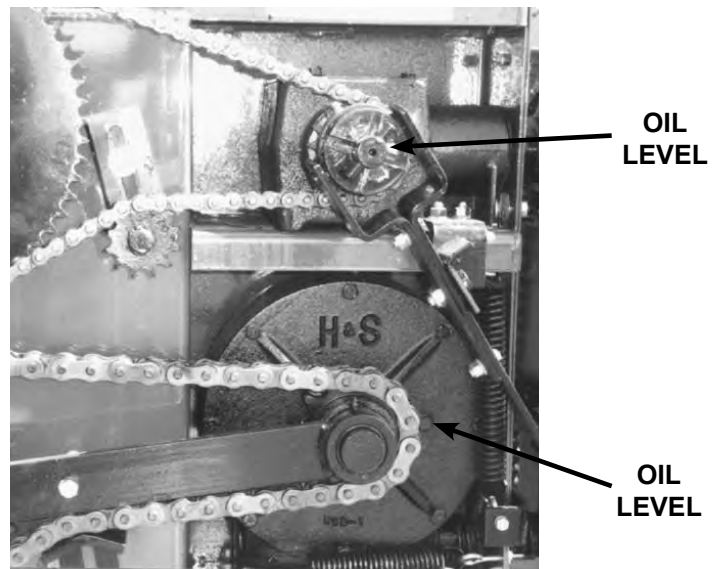

PTO ASSEMBLY

Keep the male and female shafts of the PTO well lubricated and free sliding. Failure to observe this precaution will result in excessive pressure being required to collapse or extend the assembly while subject to operating torque. This excessive force may damage the main shaft bearings. Never lubricate the shield surfaces. The shield surfaces must be kept dry, as dirt accumulation on them will cause the shields to bind and not rotate. Dented or damaged PTO shields, will also result in excessive force being applied against the jackshaft. Damaged shields also cause difficulty when installing the assembly. If at any time the shields do not turn freely, they should be checked to determine the cause, and repaired or cleaned. To avoid damage to the main drive bearings, avoid turning sharp corners while PTO is running. Start and Stop PTO slowly to avoid damage to the drive line.

LUBRICATION

- A . (2) one at each end of PTO at U-joint
- B . One on variable drive outer upper sheave
- C . One on variable drive inner lower sheave
- D . One on beater drive clutch
- E . One on sprocket type chain tightener - beater drive chain
- F . (2) one at each end of brace - gearbox to main apron drive shaft.
- G . One on cross conveyor drive shear sprocket
- H .(2) remote fittings for right hand and center main apron drive shaft bushings
- I . (6) beater bearings -one at each end of each beater (sealed bearings – DO NOT over grease)
- J . One on left hand main apron drive shaft bushing
- K . (4) one on each main apron rear idler sprocket
- L . One on beater engage bronze yoke
- M . One on Cross Conveyor belt tightener bracket (Under Shield)
- N . One on Cross Conveyor belt clutch control handle (Under Shield)

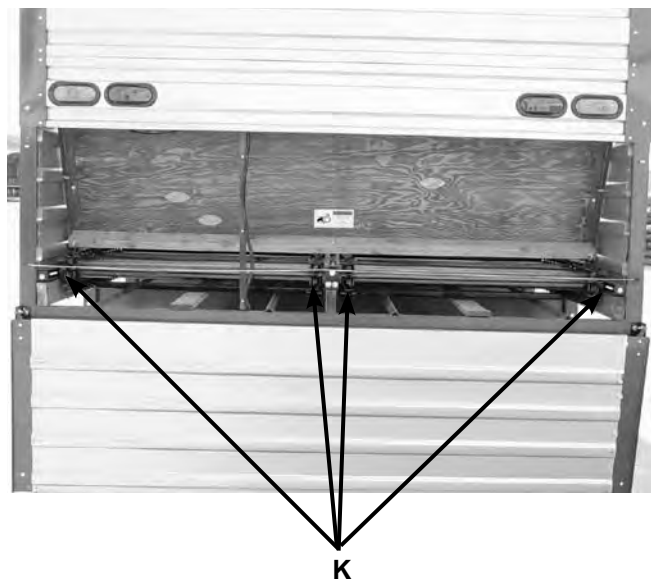
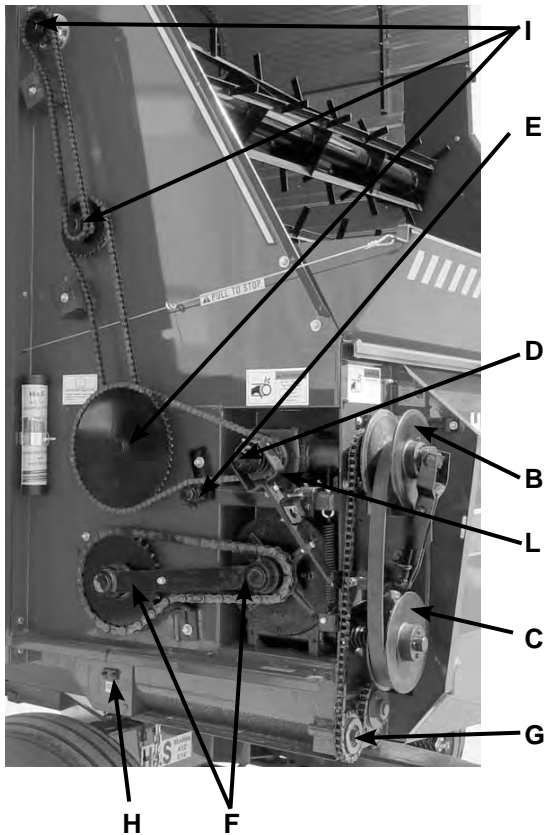
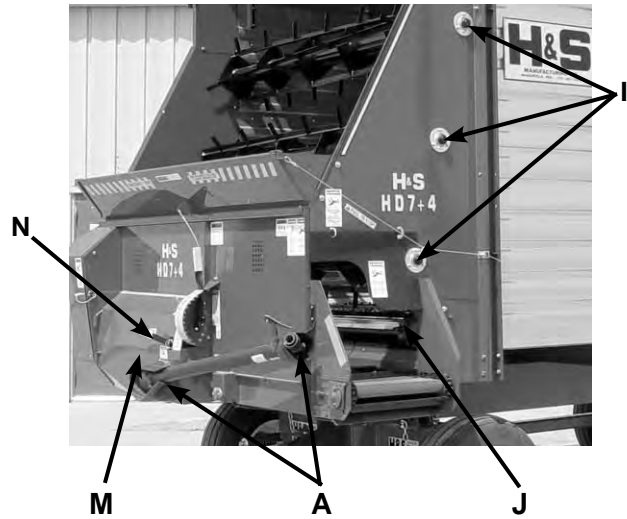

DECAL LOCATION

Your H&S Forage Box was manufactured with operator safety in mind. Located on the Forage Box are various decals to aid in operation, and to warn of danger or caution areas. Pay close attention to all the decals on your Forage Box.



DO NOT REMOVE ANY OF THESE DECALS. IF DECALS ARE LOST, DAMAGED, OR IF FORAGE BOX IS REPAINTED, REPLACE DECALS. REMEMBER: DECALS ARE FOR YOUR PROTECTION AND SAFETY.

Listed below are the decals on your Forage Box . These decals may be ordered individually by part number or by ordering a complete set.

ITEM	PART NO.	DESCRIPTION
A	1494A	Warning - Do Not Operate
AA		H&S HD 7+4
B	1494K	(2) Warning - Do Not Remove Shields
BB	5696E	Engage
C	56713	Warning - Help Avoid Injury
CC	5696D	Disengage
D	1494B	Warning - Do Not Remove Shields
DD	093020	Grease Zerk
E	5896B	Danger - Rotating Driveline
EE	093366	Manual Holder
G	1191	Beater Engage/Disengage
H	1494P	Danger - Stay Clear - Power Lines
I	1494L	Danger - PTO
J	1494H	Danger - Stay Clear
K	1043185	Push This Panel
L	5896C	Warning - Emergency Stop Reset
M	1033185	Emergency Stop
N	56842	Instruction-Entering Forage Box
O	1202177	Pull To Stop
P	11211176	Shear Bolt
R	1494C	Warning - Moving Parts Under Red
S	DCRED	Reflector
T	DCAMBER	Amber Reflector
U	B17	H&S Decal (8-1/2x17)
V	1494F	Danger - Entering Forage Box
W	7+42191	Clean Out
X	311	Patent Numbers
Z	2495	Warning - Keep Children Away

DECAL LOCATION

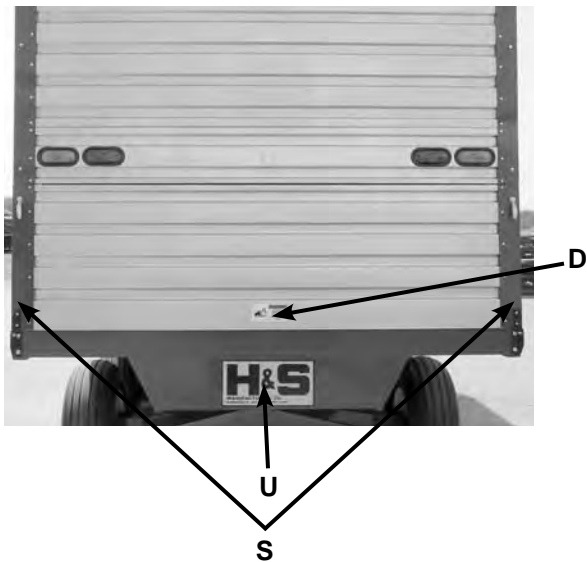
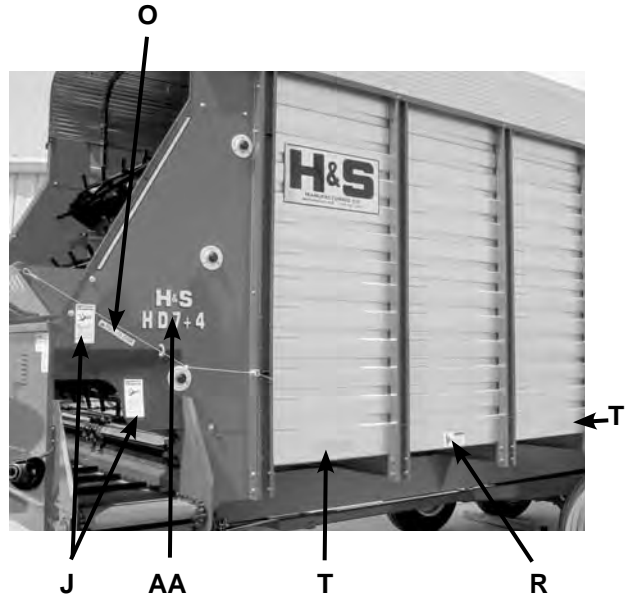
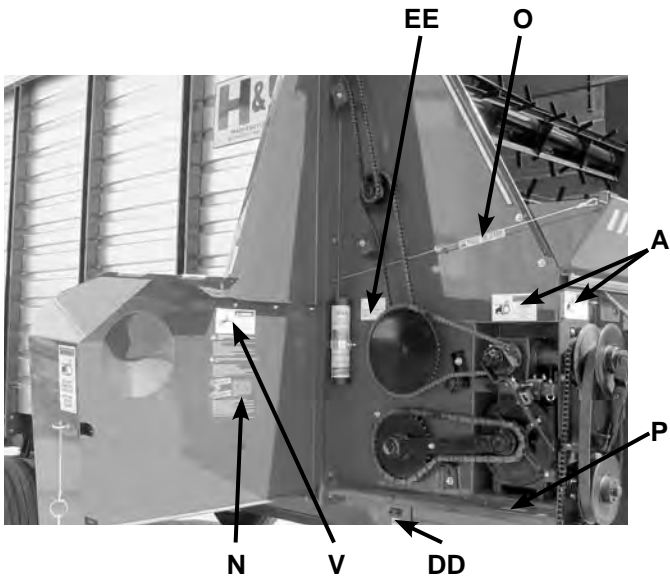
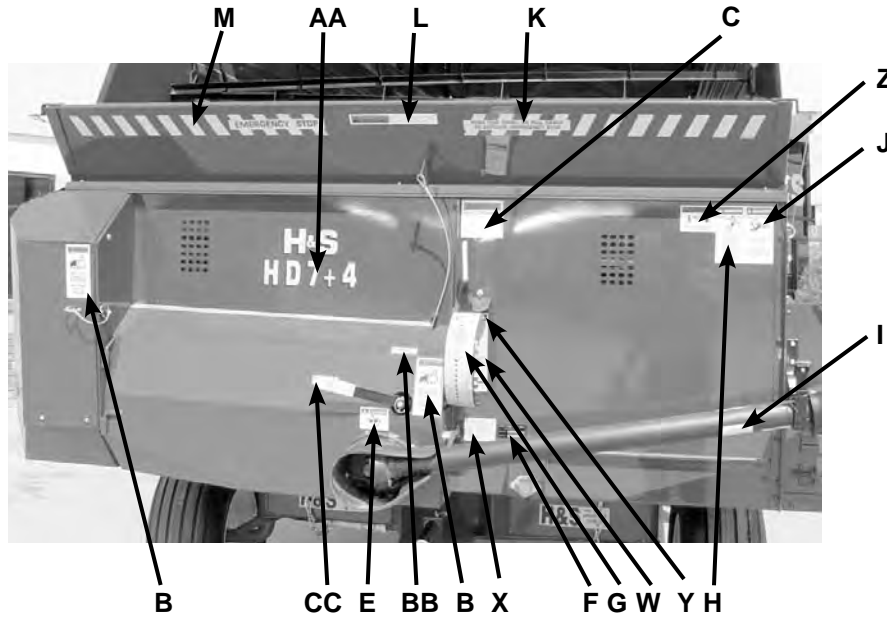

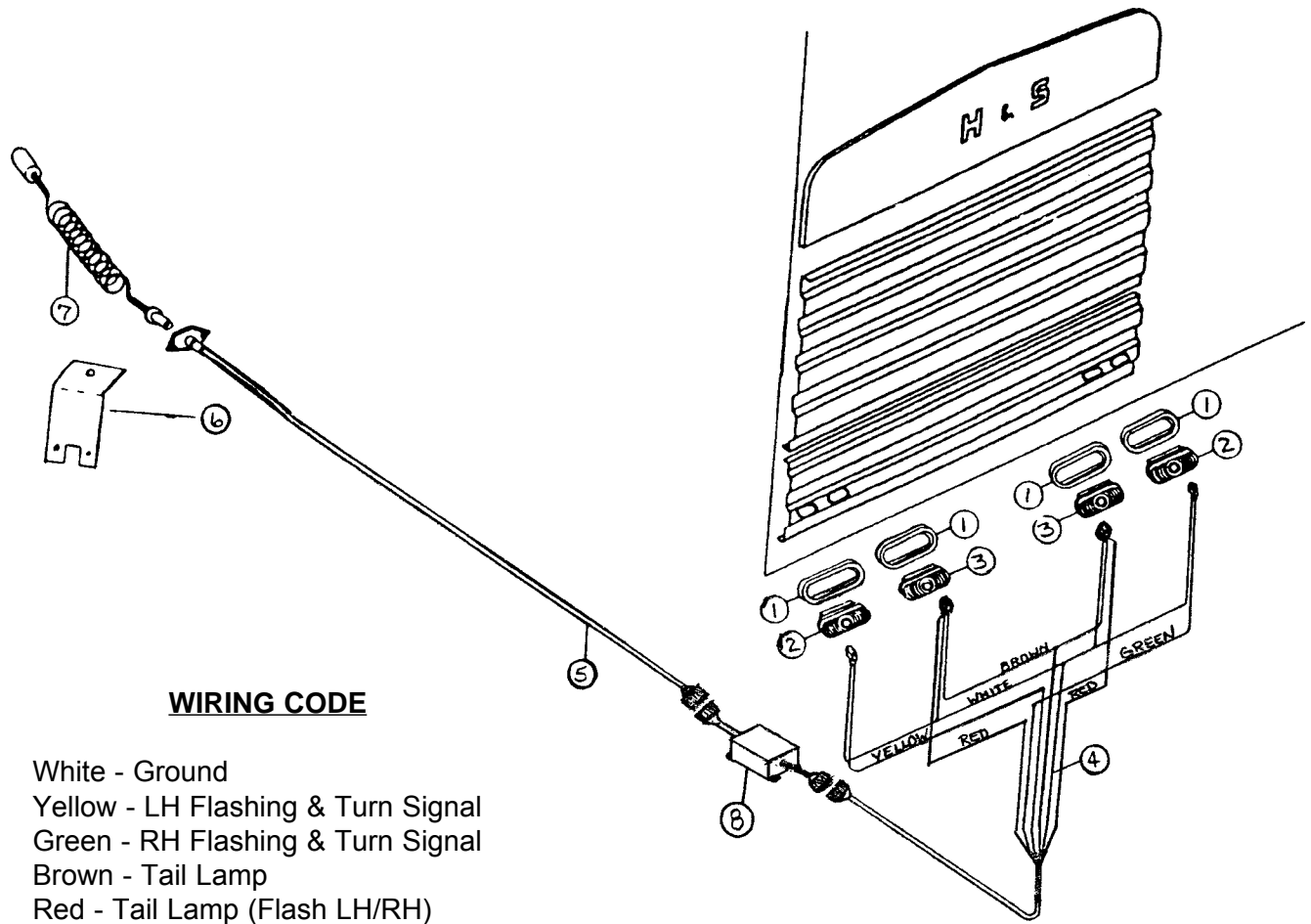
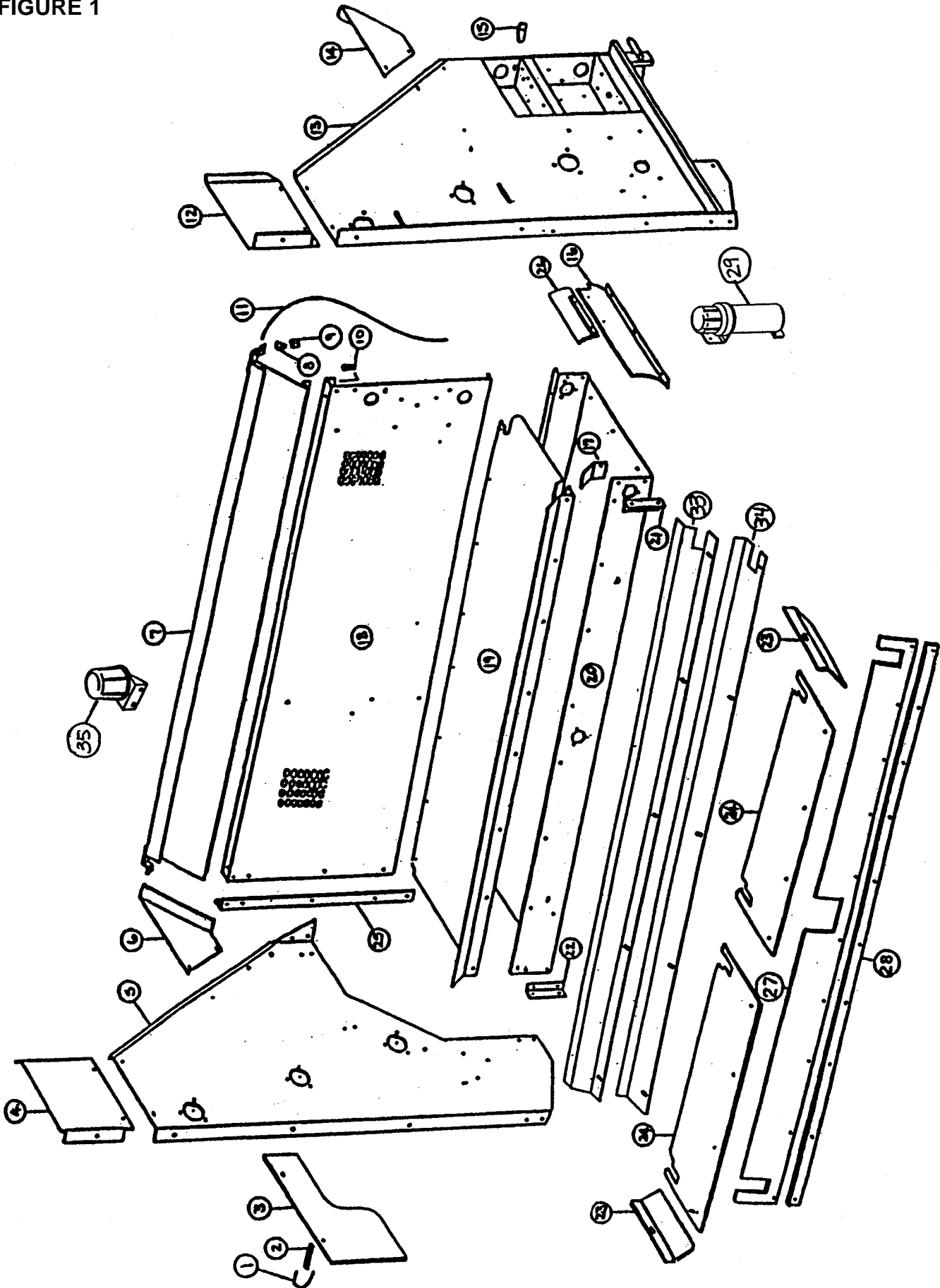

FIGURE A
H D 7+4 FORAGE BOX
LIGHTING ASSEMBLY

ITEM	PART NO.	DESCRIPTION
1 .	S308	Rubber Light Mount
2 .	S309	Amber Light
3 .	S310	Red Light
4 .	S440	Light Harness (6 Wire)
5 .	S443	14' Longitudinal Cord (4 Wire)
*	S443	16' Longitudinal Cord (4 Wire)
*	S442	18' Longitudinal Cord (4 Wire)
*	S439	20' Longitudinal Cord (4 Wire)
6 .	S346	Mounting Bracket
7 .	S317	Optional Tractor Cord
8 .	S441	Light Module
*	S445	14' Complete Light Assembly Less Optional Tractor Cord
*	S446	16' Complete Lighting Assembly Less Optional Tractor Cord
*	S447	18' Complete Lighting Assembly Less Optional Tractor Cord
*	S448	20' Complete Lighting Assembly Less Optional Tractor Cord

NOTE: * (Means Not Shown)

FIGURE 1



**FIGURE 1
HOUSING COMPONENTS FOR UNITS**

ITEM	PART NO.	DESCRIPTION
1 .	F32	U-Bolt (2)
2 .	S1	Spring for Shield (2)
3 .	S2	Plastic Beater Guard
4 .	S3	LH Side Panel Top
5 .	S4	LH Side Panel
6 .	S5	LH Emergency Stop Panel
7 .	S370	Emergency Stop Panel
8 .	ES14	Thimble (2)
9 .	ES15	Cable Clamp (2)
10 .	S7	Spring for Emergency Stop (3)
11 .	S8	Emergency Stop Cable
12 .	S9	RH Side Panel Top
13 .	S10	RH Side Panel
14 .	S11	RH Emergency Stop Panel
15 .	S12	Gear Box Brace
16 .	S13	Return Pan End
17 .	S14	Cross Apron Pan End
18 .	S353	Front Main Panel
19 .	S16	Cross Apron Pan
20 .	S356	Return Pan
21 .	S18	RH Return Pan Angle
22 .	S19	LH Return Pan Angle
23 .	S20	Apron Side Spacer
24 .	PB74	Drive Shaft Panel
25 .	S22	LH Front Angle
26 .	S217	Return Pan End
27 .	S306	Rubber Seal
28 .	S288	Rubber Seal Strap
29 .	S522	Manual Holder
33 .	S239	Cross Conv. Front Hold Down
34 .	S240	Cross Conv. Rear Hold Down
35 .	CHM38	Plug Storage

FIGURE 2

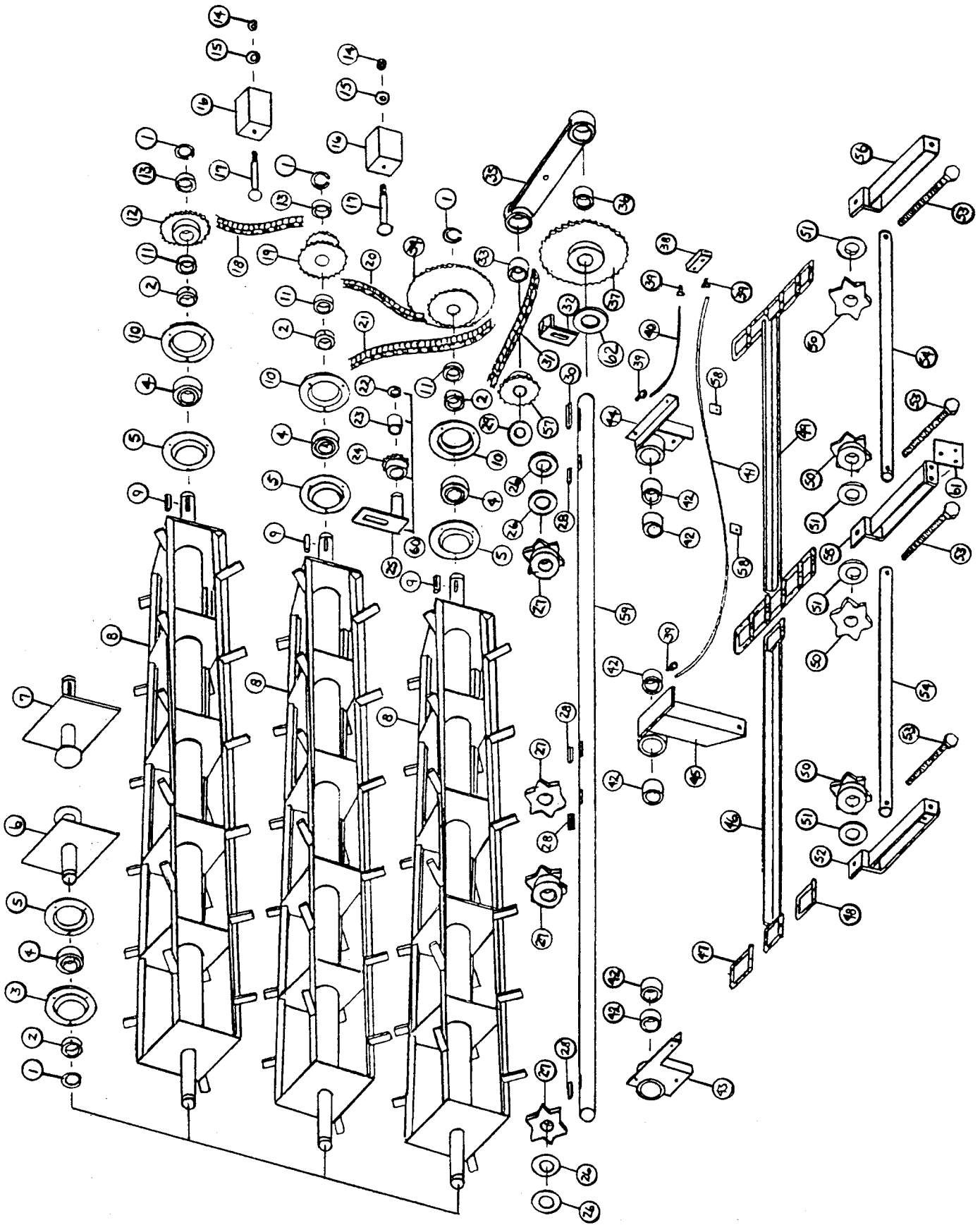

FIGURE 2
BEATERS AND MAIN APRON DRIVE

ITEM	PART NO.	DESCRIPTION	ITEM	PART NO.	DESCRIPTION
1 .	F73	Snap Ring	37 .	S45	Apron Drive Sprocket 30T
2 .	F16	Lock Collar	38 .	S46	Grease Line Bracket
3 .	F114	Bearing Flange w/Zerk	39 .	S47	Grease Line Fitting
4 .	F115	Bearing Greaseable Type	40 .	S48	Short Grease Line
5 .	F14	Bearing Flange	41 .	S49	Long Grease Line
6 .	S23	LH Beater Stub Shaft	42 .	S50	Drive Shaft Bushing
7 .	S24	RH Beater Stub Shaft	43 .	S51	LH Drive Shaft Bracket
8 .	S25	Beater	44 .	S52	RH Drive Shaft Bracket
9 .	G23	5/16" x 1-3/8" Square Key	45 .	S53	Center Bearing Bracket
10 .	F114A	Bearing Flange w/Zerk 45 Degree	46 .	S54	T-Rod Slat w/Att. Links
11 .	S218	3/8" Spacer	47 .	S55	T-Rod Standard Link
12 .	S26	3rd Beater Sprocket 20T	48 .	S56	T-Rod Connector Link
13 .	S219	1/4" Spacer		11S51	667H Pintle Connector Link
14 .	K60	Nut		11S50	667H Pintle Att. Link RH or LH
15 .	X67	Washer	49 .	S57	T-Rod Complete Apron 14'
16 .	S27	Wood Chain Tightener		S230	667H Pintle Apron 14'
17 .	S28	Carriage Bolt		S58	T-Rod Complete Apron 16'
18 .	X58	2nd to 3rd Beater Chain 89 Pitches #50		S231	667H Pintle Apron 16'
19 .	S30	2nd Beater Sprocket 30T - 13T		S59	T-Rod Complete Apron 18'
20 .	S31	1st to 2nd Beater Chain 98 Pitches #50		S232	667H Pintle Apron 18'
21 .	X58	Beater Drive Chain 89 Pitches #50		S422	T-Rod Complete Apron 20'
22 .	10R32	Snap Ring		S432	667H Pintle Apron 20'
23 .	S33	Chain Tightener Bushing	50 .	S60	Real Idler Sprocket
24 .	S34	Tightener Sprocket w/Bushing	51 .	S61	Idler Shaft Spacer
25 .	L10R35	Chain Tightener Bracket	52 .	S62	LH Rear Idler Bracket
26 .	S36	Drive Shaft Spacer	53 .	A7	Tightener Bolt
27 .	S37	Apron Drive Shaft Sprocket	54 .	S63	Rear Idler Shaft
28 .	S436	3/8" x 1-1/2" Square Key	55 .	S64	Center Idler Bracket
29 .	S327	Poly Gearbox Washer	56 .	S65	RH Rear Idler Bracket
30 .	S38	3/8" x 2-3/8" Square Key	57 .	ST11	Worm Gear Shaft Sprocket 13T
31 .	ST10	Apron Drive Chain 56 Pitches #80		S66	Slow Down Sprocket 11T
32 .	S40	Chain Tightener	58 .	S67	Grease Line Clip
33 .	S41	Bushing	59 .	S68	Main Apron Drive Shaft
34 .	S42	1st Beater Sprocket 60T-20T	60 .	S216	Chain Tightener Assembly
35 .	S43	Drive Shaft Brace	61 .	S371	Cable Bracket
36 .	S44	Bushing	62 .	S409	Drive Shaft Shim
NOT SHOWN					
			F157	#80 Connector Link	
			F158	#80 Offset Link	

FIGURE 3

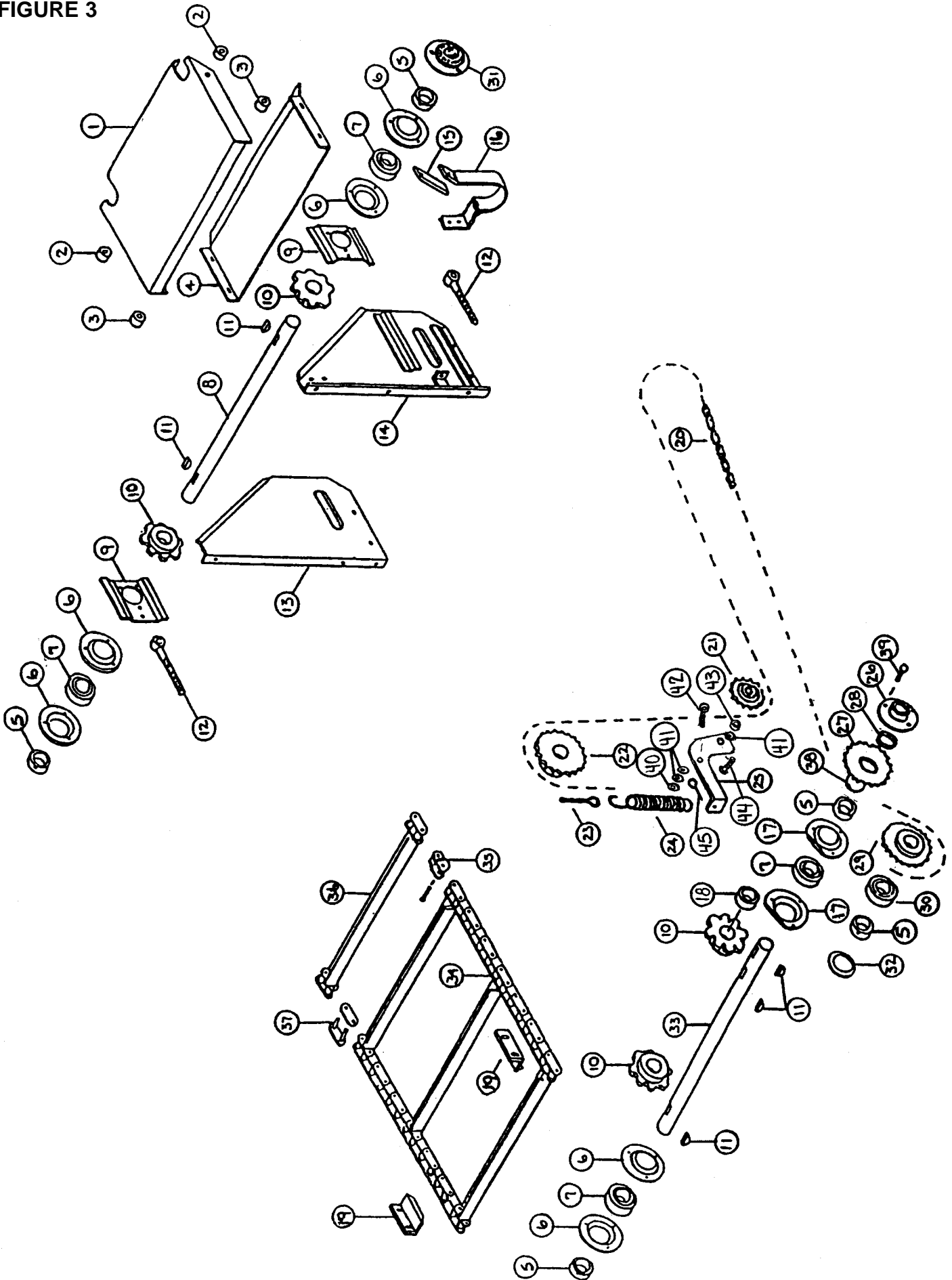

FIGURE 3
CROSS APRON AND DRIVE ASSEMBLY

ITEM	PART NO.	DESCRIPTION
1.	S69	Cross Apron Pan Extension
2.	S70	Spacer
3.	S71	Pan Extension Carrier
4.	S72	Return Pan Extension
5.	4C9	Lock Collar
6.	4C7	Bearing Flange
7.	4C8	Bearing
8.	S73	Cross Apron Idler Shaft
9.	S74	Tightener Bracket
10.	L10R24	8 Tooth Sprocket
11.	5B10	1/4" x 1" Woodruff Key
12.	S75	Tightener Bolt
13.	S76	Tightener Panel Rear
14.	S77	Tightener Panel Front
15.	S78	PTO Holder Rubber Tab
16.	S354	PTO Holder
17.	X85	Bearing Flange Sheared
18.	K132	3/8" Spacer
19.	S223	Cross Conveyor Hold down
20.	S357	Front Drive Chain 193 Pitch #50
21.	K101	Tightener Sprocket 17T
22.	S82	Sprocket 24T
23.	ES10	5/16" x 3" I-Bolt
24.	ST36	Spring
25.	S459	Tightener Bracket
26.	S391	Shear Hub
27.	S392	Sprocket 24T
28.	S393	Bronze
29.	K89	Idler Sprocket 20T
30.	K90	Bearing
31.	S87	Cross Apron Shaft Guard
32.	K92	Snap Ring
33.	S390	Cross Apron Drive Shaft
34.	S89	Cross Conveyor
35.	K122	550 Offset Link Cross Conveyor
36.	K120	550 Slat w/Attached Links
37.	K121	550 Connector Link Cross Conveyor
38.	S394	Snap Ring
39.	RGB38	Shear Bolt 5/16" x 1" GR.2
*	X60	#50 Offset Link
*	X61	#50 Connector Link
40.	A34	Washer 1/2"
41.	S468	Washer
42.	16SV126	Counter Sunk Bolt 2"
43.	R65	Spacer 3/8"
44.	S467	Count Sunk Bolt 2-1/4"
45.	K79	Eye Bolt

NOTE: * (Means Not Shown)

FIGURE 4

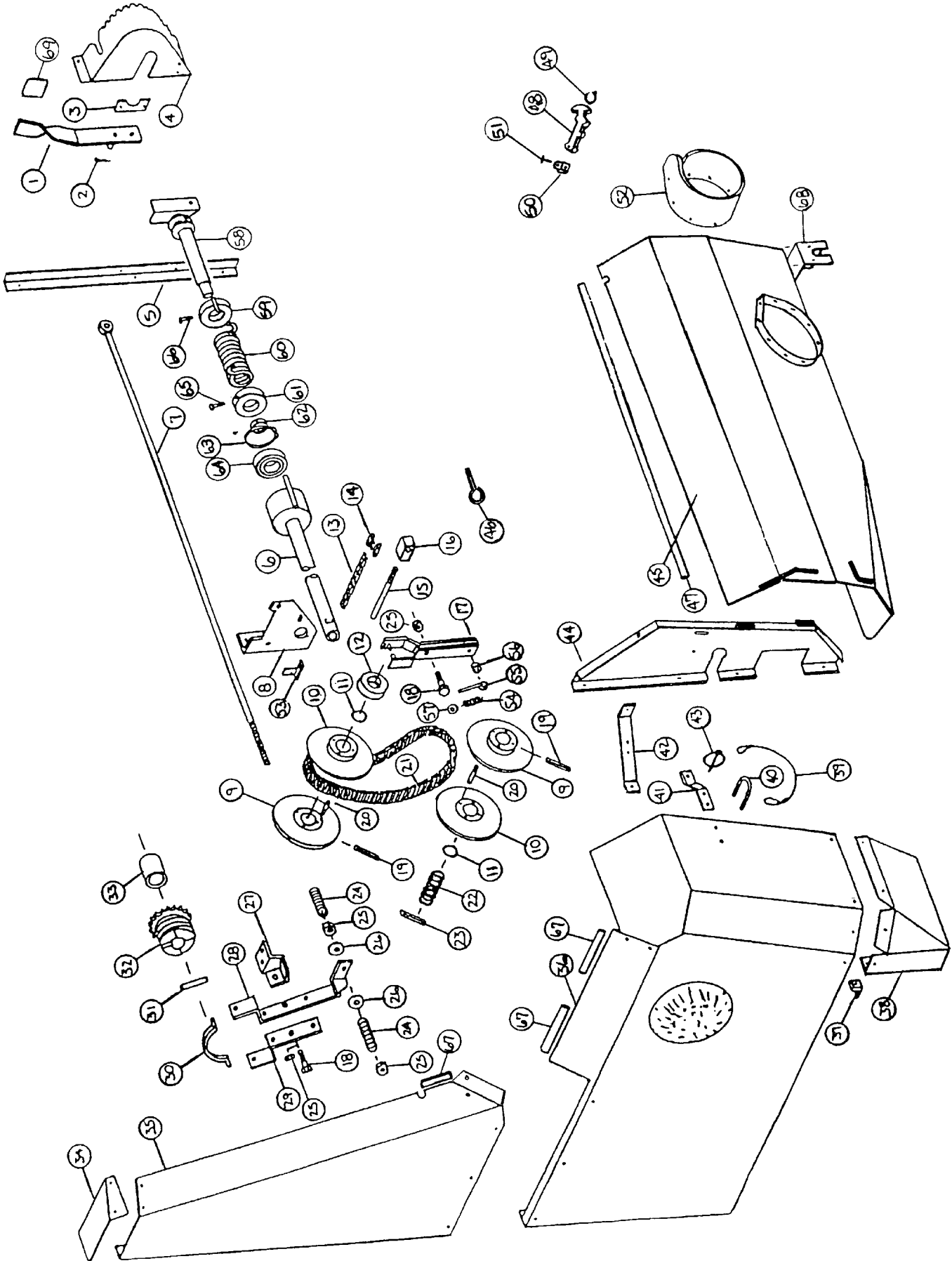

FIGURE 4
SHIELDS - BEATER CLUTCH - BELT DRIVE

ITEM	PART NO.	DESCRIPTION	ITEM	PART NO.	DESCRIPTION
1 .	S364	Shifter Handle	36 .	S120	Main Side Shield
2 .	X43	Cotter Pin	37 .	D58	Shield Angle
3 .	S91	Shifting Pipe Bracket	38 .	S121	Side Shield Bottom
4 .	S360	Speed Selector Panel	39 .	S122	Clip Pin Cable
5 .	S365	Front Center Angle	40 .	F32	U-Bolt
6 .	S366	Shifting Pipe (Apron)	41 .	S123	Shield Latch Bracket
7 .	S367	Shifting Rod (Beater)	42 .	S234	Shield Brace
8 .	S96	Shifting Bracket	43 .	F56	Clip Pin
9 .	S97	Stationary Sheave	44 .	S333	Front Upright Shield
10 .	S295	Sliding Sheave	45 .	S334	Front Shield
11 .	S99	O-Ring	46 .	BFR319	I-Bolt
12 .	S100	Thrust Bearing	47 .	S359	Edging 38"
13 .	S101	#40 Chain 5 Pitch	48 .	X192	Front Shield Latch (Rubber)
14 .	S102	#40 Connector Link	49 .	X193	Latch Catch Bracket
15 .	S103	Linkage Rod	50 .	X194	Latch Mounting Bracket
16 .	S104	Adjustment Block	51 .	X195	Pin
17 .	S105	Variable Speed Shifter	52 .	S131	PTO Rubber Shield
18 .	R10	1/2" x 1-1/4" Bolt GR.5	53 .	S221	Spring Shift Bracket
19 .	S106	5/16" x 2-3/4" Expansion Pin	54 .	S222	Shifting Spring
20 .	S296	Sheave Pin	55 .	S220	Shifting Spring Rod
21 .	S108	Variable Speed Belt	56 .	K94	Spacer
22 .	S109	Spring	57 .	T16	1/4" Flat Washer
23 .	S110	1/4" x 2" Expansion Pin	58 .	S290	Shifter Handle Pipe End
24 .	S111	Spring	59 .	S291	Spring Pin Collar
25 .	9S17	1/2" Lock Nut	60 .	S292	Spring
26 .	S285	Beater Clutch Washer	61 .	S293	Spring Collar
27 .	S112	Beater Clutch Bracket	62 .	4C9	Lock Collar
28 .	S113	Beater Clutch Long Arm	63 .	K92	Snap Ring
29 .	S114	Beater Clutch Short Arm	64 .	K90	Bearing
30 .	ST58	Clutch Yoke	65 .	17G141	Bolt 3/8" x 1-1/4" GR.5
31 .	S115	Beater Clutch Pin	66 .	X111	Bolt 3/8" x 1" GR.5
32 .	S116	Beater Clutch Sprocket	67 .	S328	Edging 3-1/2"
33 .	S117	Beater Clutch Bushing	68 .	S346	Mounting Bracket
34 .	S118	Beater Shield Top	69 .	S403	Handle Grip
35 .	S119	Beater Side Shield	*	S368	Complete Shifter

NOTE: * (Means Not Shown)

FIGURE 5

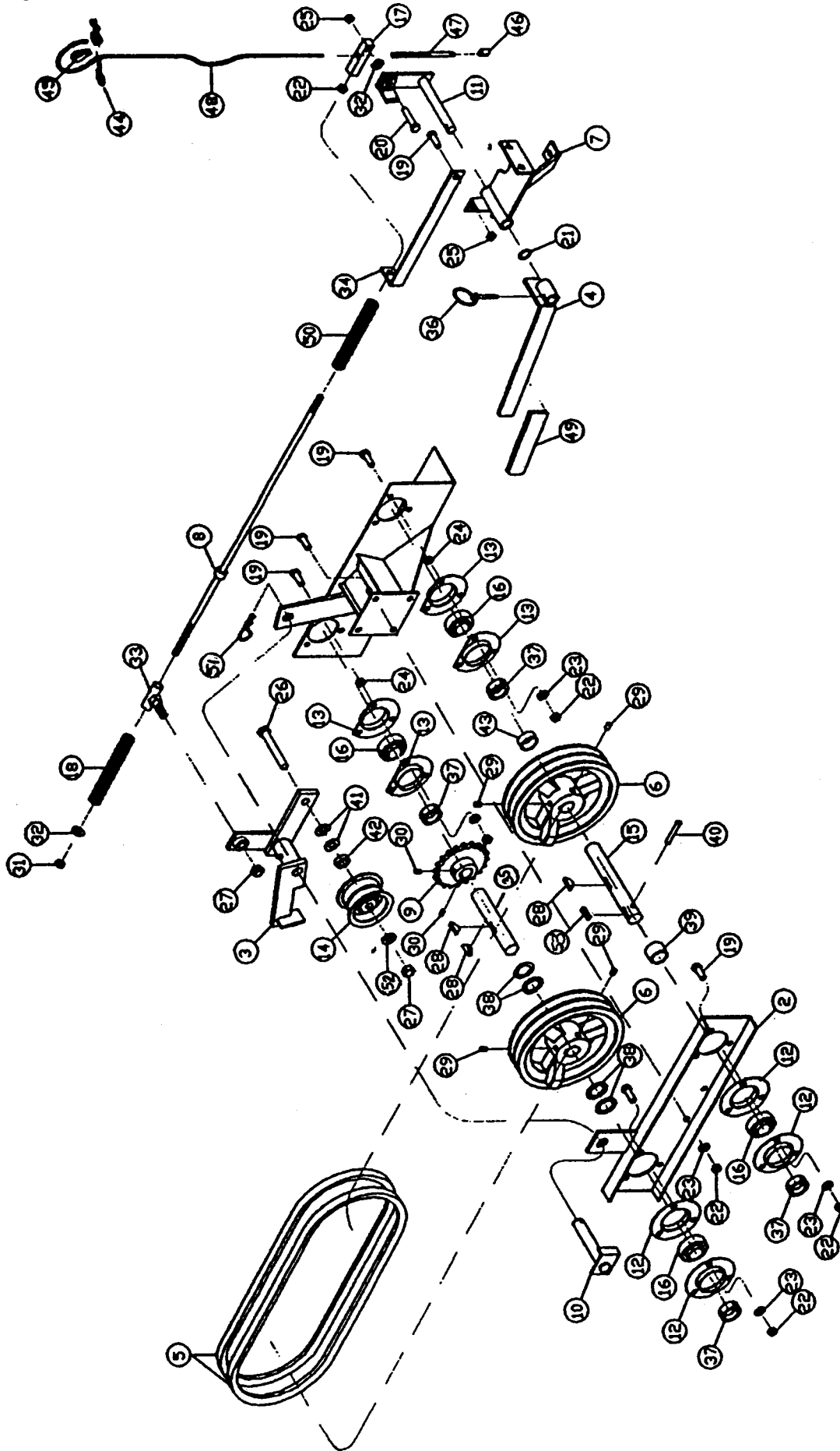
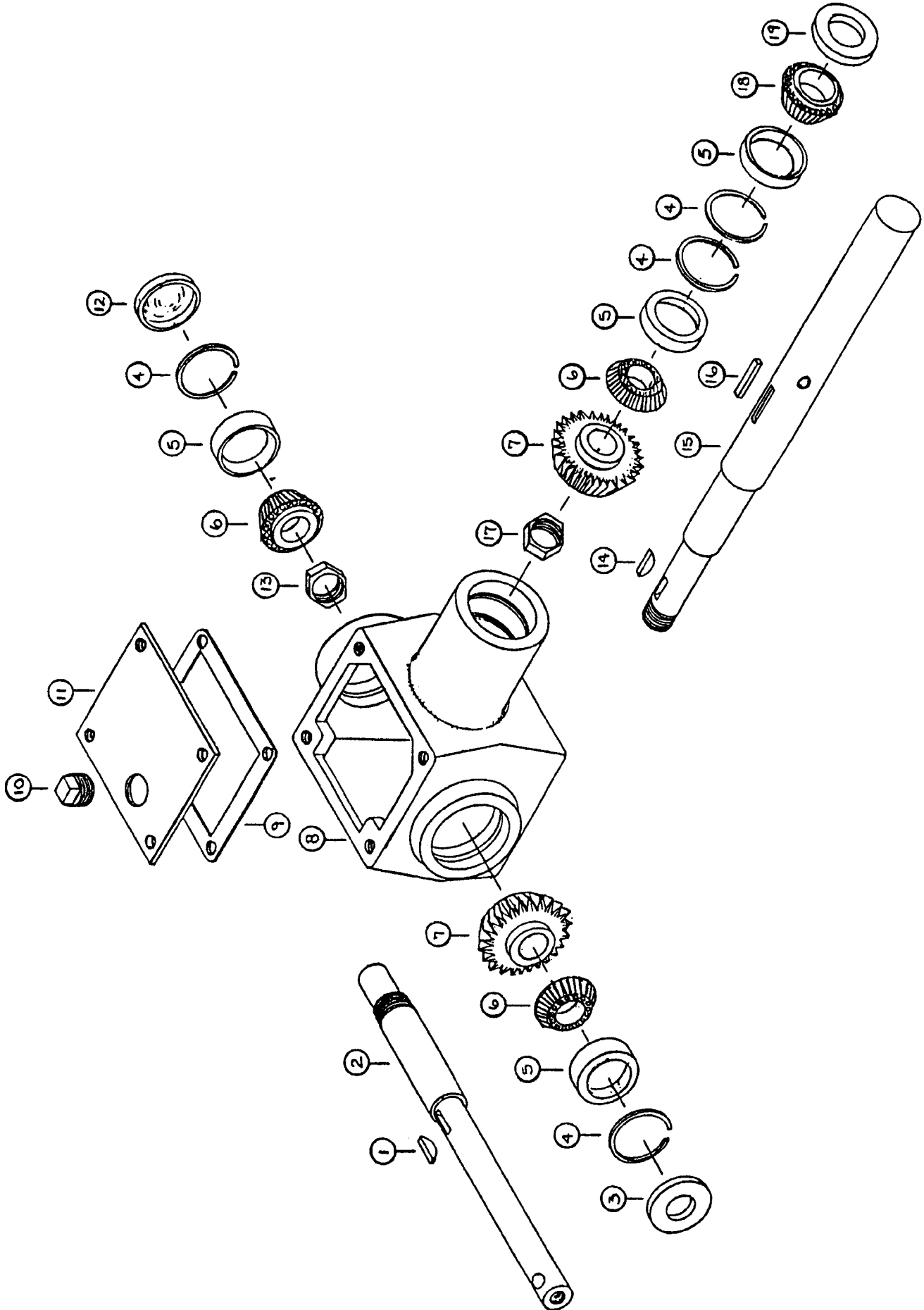

FIGURE 5
CROSS CONVEYOR CLUTCH - BELT DRIVE

ITEM	PART NO.	DESCRIPTION
2 .	S335	Front Clutch Plate
3 .	S341	Idler-Stop Assembly
4 .	S337	Handle Lever
5 .	S332	Drive Belt Set
6 .	S342	Pulley
7 .	S339	Handle Mount
8 .	S343	Shifting Rod
9 .	11S19	Sprocket 50B20
10 .	S340	Tightener Pivot Shaft
11 .	S338	Handle Lever
12 .	4C7	Bearing Flange
13 .	X85	Bearing Flange Sheared
14 .	K156	Idler Pulley
15 .	S458	Input Pulley Shaft
16 .	4C8	Bearing
17 .	S347	Shifter Rod End
18 .	23N211	Spring 3/4"
19 .	X111	3/8" x 1" Bolt GR.5
20 .	BFR320	3/8"x 1-3/4" Bolt GR.2
21 .	S352	Internal Star Washer
22 .	K60	3/8" Nut
23 .	B68	3/8" Lockwasher
24 .	S355	3/8" Jam Nut
25 .	K25	3/8" Locknut
26 .	16SV91	1/2" x 3-1/4" Bolt GR.5
27 .	R11	1/2" Top Locknut
28 .	5B10	1/4" x 1" Woodruff Key
29 .	---	3/8" Setscrew
30 .	---	5/16" Setscrew
31 .	A14	3/8" Nylock Nut
32 .	X67	3/8" Flatwasher
33 .	S344	Clutch Rod Slide
34 .	S348	Spring Bracket
35 .	S349	Drive Pulley Shaft
36 .	S438	Clip Pin
37 .	4C9	Bearing Lock Collar
38 .	S345	Spacer (.074)
39 .	K99	Spacer, 7/8"
40 .	BFR335	5/16" x 2" Expansion Pin
41 .	K68	1/2" Lockwasher
42 .	X112	Spacer, 9/16"
43 .	K106	Spacer, 1/2"
44 .	BFR220	Cable Clamp
45 .	ES4	Thimble
46 .	ES5	Cable Compression Sleeve
47 .	S361	Stop Cable Stiffener
48 .	S358	Emergency Stop Cable
49 .	S362	Handle Lever Grip
50 .	S369	Spring 5/8"
51 .	ES7	Hair Pin
52 .	R35	1/2" Lock Washer (As Needed)
53 .	S135	1/4" x 1-1/4" Square Key

FIGURE 6



**FIGURE 6
BEVEL GEARBOX**

ITEM	PART NO.	DESCRIPTION
1 .	5B10	1/4" x 1" Woodruff Key
2 .	S132	Gearbox Side Shaft
3 .	3G9	Seal
4 .	3G19	Snap Ring
5 .	3G18	Race #15245
6 .	3G7	Bearing #15101
7 .	3G5	Gear
8 .	3G1	Gearbox Housing
9 .	3G2	Gearbox Gasket
10 .	3G20	Fill Plug
11 .	3G3	Cover
12 .	X2	Dust Cap
13 .	3G11	Nut
14 .	5B10	1/4" x 1" Woodruff Key
15 .	S134	Gear Box Front Shaft
16 .	S135	1/4" x 1-1/4" Square Key
17 .	3G4	Nut
18 .	L3G24	Gearbox Bearing #15113
19 .	S136	Seal
*	S137	Bevel Gearbox Complete

NOTE: * (Indicates Not Shown Assembled)

FIGURE 7

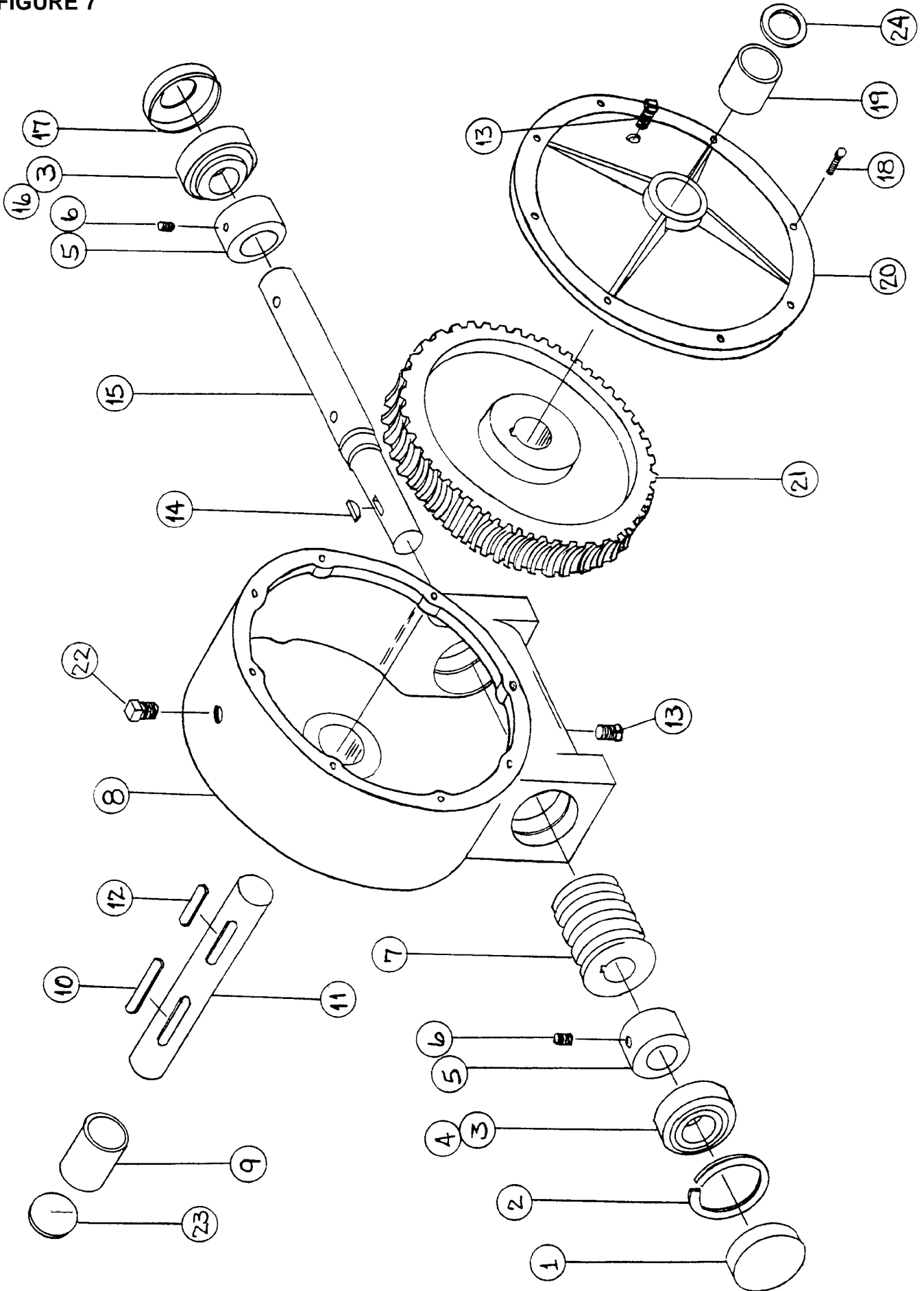
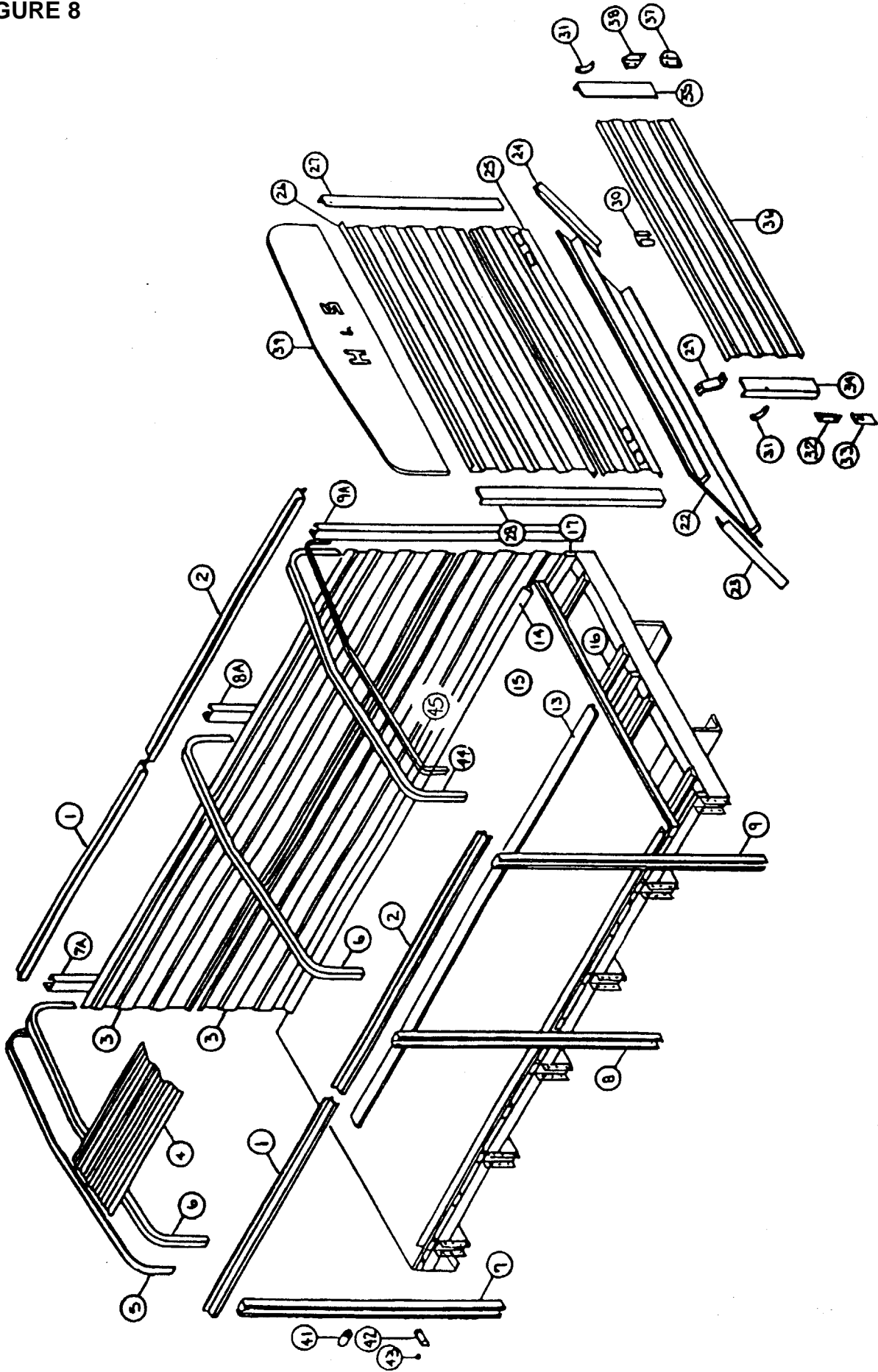

FIGURE 7
WORM GEARBOX

ITEM	PART NO.	DESCRIPTION
1 .	G90	Dust Cap
2 .	3G19	Snap Ring
3 .	3G18	Race #15245
4 .	3G7	Bearing #15101
5 .	X9	Spacer
6 .	G83	Set Screw
7 .	G76	Worm
8 .	G114	Geabox Housing
9 .	X8	Gearbox Bushing
10 .	S138	3/8 x 2-3/8" Square Key w/Round Ends
11 .	S139	Worm Gear Side Shaft
12 .	S437	3/8 x 1-3/8" Square Key w/Round Ends
13 .	G65	Plug 3/8"
14 .	5B10	1/4 x 1" Woodruff Key
15 .	S140	Worm Gear Front Shaft
16 .	L3G24	Gear Box Bearing #15113
17 .	G115	Seal
18 .	G84	Cap Screw
19 .	X75	Cover Bushing
20 .	G116	Worm Gearbox Cover
21 .	G77	Worm Gear
22 .	G91	Vent Plug
23 .	G117	Cap
24 .	G120	Seal 1-7/8"
*	G118	Worm Gearbox Complete

NOTE: * (Indicates Not Shown Assembled)

FIGURE 8



**FIGURE 8
BOX COMPONENTS**

ITEM	PART NO.	DESCRIPTION	ITEM	PART NO.	DESCRIPTION	
1 .	S142	14' Roof Sill Front Section	15 .	S428	20' Apron Chain Side Spacer	
	S143	16' Roof Sill Front Section		S489	21' Apron Chain Side Spacer	
	S470	17' Roof Sill Front Section		S507	22' Apron Chain Side Spacer	
	S144	18' Roof Sill Front Section		S168	14' Floor Assembly	
	S471	19' Roof Sill Front Section		S169	16' Floor Assembly	
2 .	S423	20' Roof Sill Front Section	16 .	S490	17' Floor Assembly	
	S472	21' Roof Sill Front Section		S170	18' Floor Assembly	
	S502	22' Roof Sill Front Section		S491	19' Floor Assembly	
	S145	14' Roof Sill Back Section		S429	20' Floor Assembly	
	S146	16' Roof Sill Back Section		S492	21' Floor Assembly	
	S473	17' Roof Sill Back Section		S508	22' Floor Assembly	
	S147	18' Roof Sill Back Section		S408	14' Apron Chain Return Slide	
3 .	S474	19' Roof Sill Back Section	17 .	S271	16' Apron Chain Return Slide	
	S424	20' Roof Sill Back Section		S493	17' Apron Chain Return Slide	
	S475	21' Roof Sill Back Section		S272	18' Apron Chain Return Slide	
	S503	22' Roof Sill Back Section		S494	19' Apron Chain Return Slide	
	S148	14' Side Steel		S430	20' Apron Chain Return Slide	
	S149	16' Side Steel		S495	21' Apron Chain Return Slide	
	S476	17' Side Steel		S509	22' Apron Chain Return Slide	
	S150	18' Side Steel		S174	14' Floor Support 2x4	
	S477	19' Side Steel		S175	16' Floor Support 2x4	
	S425	20' Side Steel		S496	17' Floor Support 2x4	
4 .	S478	21' Side Steel	22 .	S176	18' Floor Support 2x4	
	S504	22' Side Steel		S497	19' Floor Support 2x4	
	S151	14' Roof Steel (5)		S431	20' Floor Support 2x4	
	S152	16' Roof Steel (5)		S498	21' Floor Support 2x4	
	S479	17' Roof Steel		S510	22' Floor Support 2x4	
	S153	18' Roof Steel (5)		S184	Rear Slant Panel	
	S480	19' Roof Steel		S185	LH Angle for Slant Panel	
	S426	20' Roof Steel		S186	RH Angle for Slant Panel	
5 .	S481	21' Roof Steel	23 .	S307	Back Door Center Steel	
	S505	22' Roof Steel		S188	Back Door Upper Steel	
	S154	Branch Guard (14'-16')		S189	Back Door RH Side Piece	
	5A .	Branch Guard (18'-20'-22')		S190	Back Door LH Side Piece	
	5B .	Branch Guard (17'-19'-21')		S191	Slant Panel Brace	
	S155	Roof Support (14'-16')		F97	SMV Holder	
	6A .	Roof Support (18'-20'-22')		S192	Handle Nut	
	6B .	Roof Support (17'-19'-21')		S193	LH Hinge Top Piece	
	7 .	LH Front Stake		S194	LH Hinge Bottom Piece	
	7A .	RH Front Stake		S195	Tailgate LH Side Piece	
8 .	ST49	LH Side Stake	34 .	S196	Tailgate RH Side Piece	
	8A .	RH Side Stake		S197	Tailgate Steel	
	9 .	LH Back Stake		S198	RH Hinge Bottom Piece	
	9A .	RH Back Stake		S199	RH Hinge Top Piece	
	13 .	S162		14' Apron Chain Center Spacer	S453	Back Door Top Panel (14'-16')
	S163	16' Apron Chain Center Spacer		39A .	S454	Back Door Top Panel (18'-20'-22')
	S484	17' Apron Chain Center Spacer		39B .	S499	Back Door Top Panel (17'-19'-21')
	S164	18' Apron Chain Center Spacer		41 .	ST55	Stake Spacer
	S485	19' Apron Chain Center Spacer		42 .	ST56	Cable Bracket
	S427	20' Apron Chain Center Spacer		43 .	ST57	Plastic Grommet for Cable
14 .	S486	21' Apron Chain Center Spacer	44 .	S235	Rear Roof Support (14'-16')	
	S506	22' Apron Chain Center Spacer		S236	Rear Roof Support (18'-20'-22')	
	S165	14' Apron Chain Side Spacer		S500	Rear Roof Support (17'-19'-21')	
	S166	16' Apron Chain Side Spacer		S154	Rear Branch Guard (14'+16')	
	S487	17' Apron Chain Side Spacer		45A .	ST61	Rear Branch Guard (18'-20'-22')
	S167	18' Apron Chain Side Spacer		45B .	S501	Rear Branch Guard (17'-19'-21')
	S488	19' Apron Chain Side Spacer				

FIGURE 9

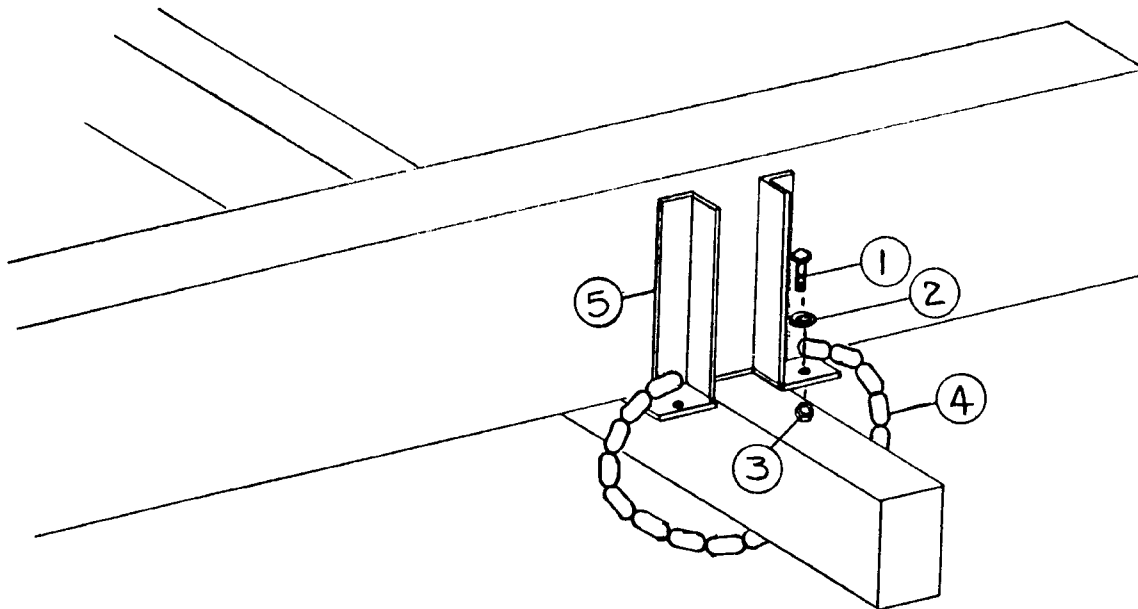

TIE DOWN KIT

ITEM	PART NO.	DESCRIPTION
1.	12V45	1/2" x 1-1/2" GR.5 Bolt
2.	K68	1/2" Flat Washer
3.	R11	1/2" Top Lock Nut GR.5
4.	S322	1/4" Chain 30-1/4" Long
5.	S323	Tie Down Bracket
*	T9B	Tie Down Kit (Complete)

NOTE: * (Means Not Shown)

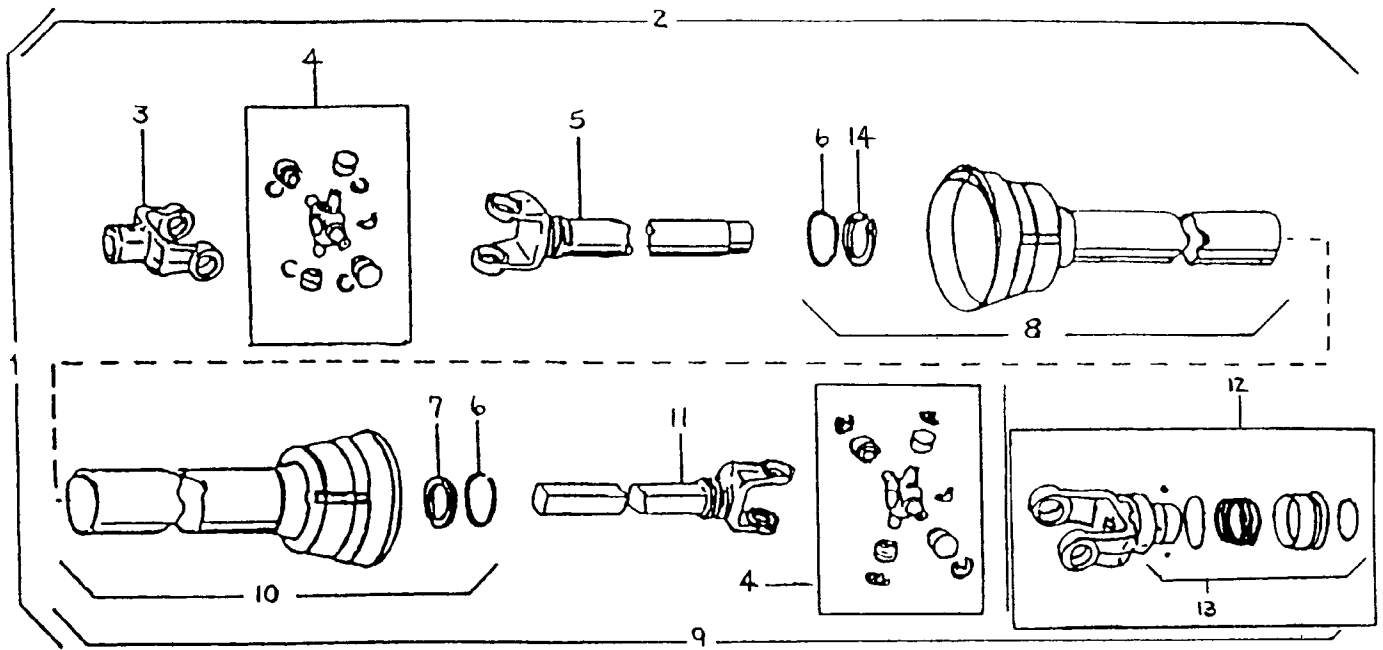

FIGURE 10
PTO PARTS
HD NEEDLE BEARING PTO

ITEM	PART NO.	DESCRIPTION
1.	S372	PTO Assembly Complete
2.	S373	Machine Half PTO W/Shield
3.	S374	End Yoke - Machine Half
4.	S375	"W" Repair Kit
5.	S376	Yoke and Tube
6.	24N26	Bearing Retainer
7.	S206	Nylon Bearing
8.	S397	Inner Guard Includes Cent. & Item #6 & #14
9.	S377	Tractor Half PTO
10.	S398	Outer Guard Includes Item #6 & #7
11.	S378	Yoke and Shaft
12.	S379	Lock Yoke - Yoke Assembly
13.	S225	Spring Lock Repair Kit
14.	S396	Nylon Bearing
15.	S402	Safety Manual

FIGURE 11

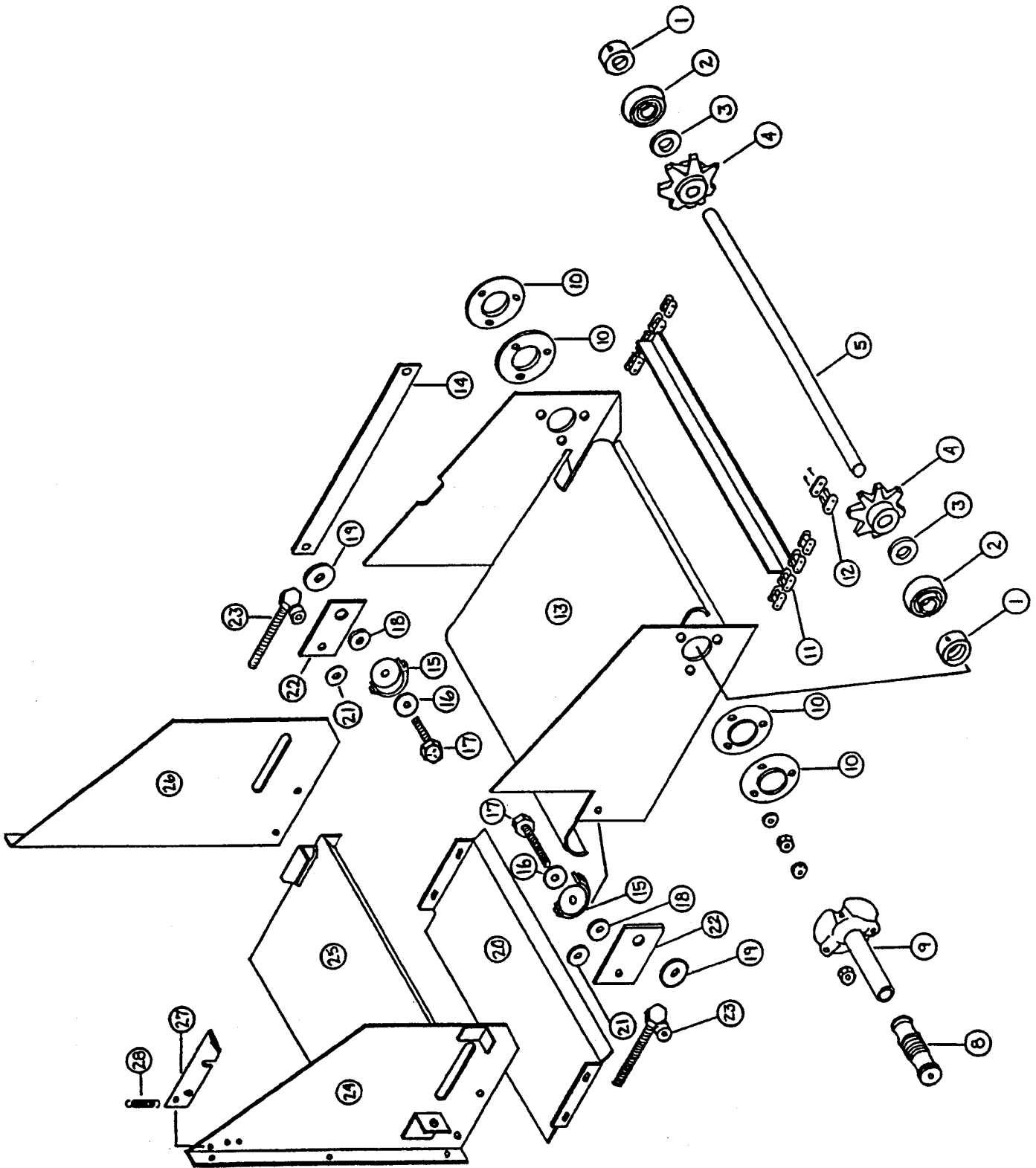
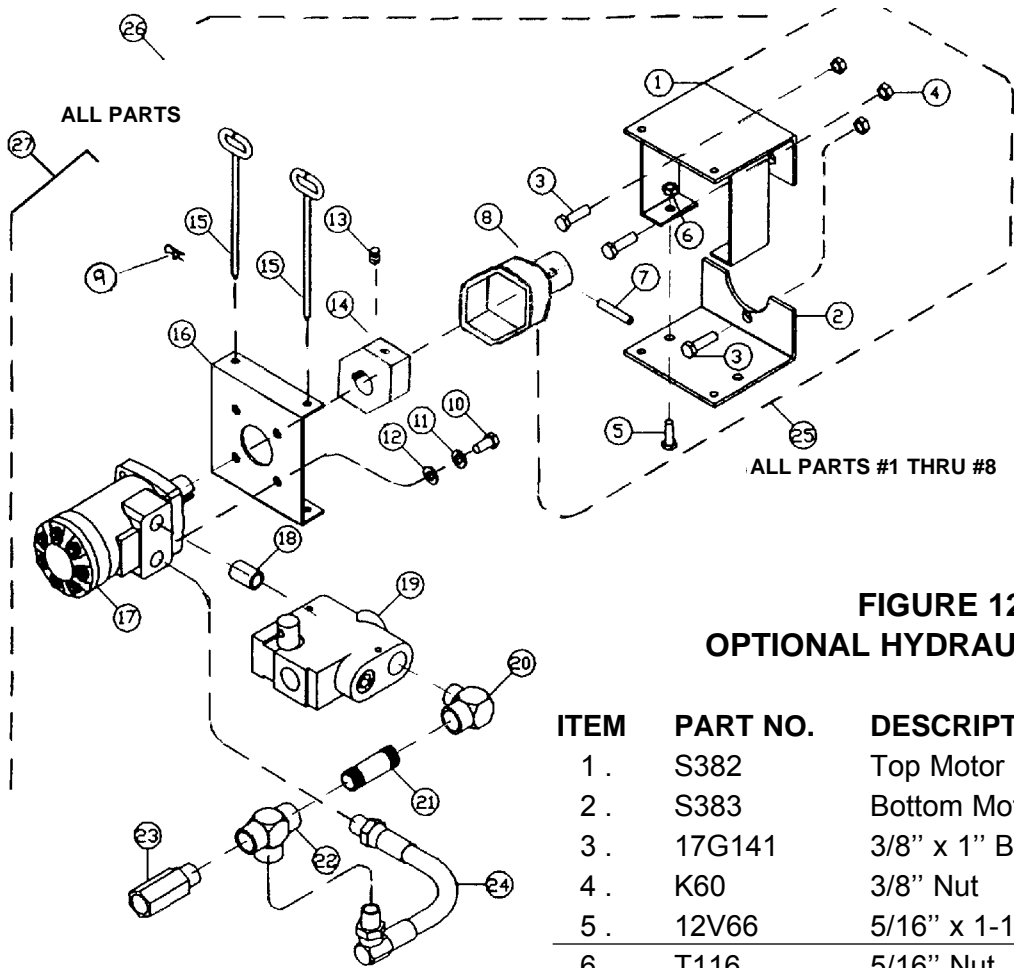

FIGURE 11
H&S MODELS H D 7+4 OPTIONAL 12" EXTENSION

ITEM	PART NO.	DESCRIPTION
1 .	4C9	Lock Collar
2 .	4C8	1" Bearing
3 .	BFR33	Spacer
4 .	S417	8T Sprocket
5 .	S238	Extension Idler Shaft
8 .	X41	Handle Grip
9 .	S241	Handle
10 .	4C7	Bearing Flange
11 .	S242	Cross Conveyor
12 .	K121	Connector Link
13 .	S243	Main Shell
14 .	S244	Extension Brace
15 .	S245	Chain Slide Assembly
16 .	A34	Washer
17 .	F52	Bolt Grade 5-1/2 x 2"
18 .	S246	Extension Shell Hinge
19 .	S247	Extension Washer
20 .	S248	Pan Extension
21 .	S249	Extension Shell Spacer
22 .	S250	Extension Side Plates
23 .	S251	Extension Tightener Bolt
24 .	S252	Extension Front Panel
25 .	S253	Extension Slider Pan Assembly
26 .	S254	Extension Back Panel
27 .	S255	Extension Latch
28 .	12R3	Spring



**FIGURE 12
OPTIONAL HYDRAULIC DRIVE**

ITEM	PART NO.	DESCRIPTION
1.	S382	Top Motor Hanger
2.	S383	Bottom Motor Hanger
3.	17G141	3/8" x 1" Bolt
4.	K60	3/8" Nut
5.	12V66	5/16" x 1-1/4" GR.5 Bolt
6.	T116	5/16" Nut
7.	3G22	5/16" x 1-3/4" Roll Pin
8.	S411	Secondary Drive
9.	X97	Hair Pin
10.	G110	3/8" x 3/4" Bolt
11.	B68	3/8" Lockwasher
12.	X67	3/8" Flat Washer
13.	---	5/16" Set Screw
14.	S410	Primary Drive
15.	S386	Motor Unit Mount Pin
16.	S384	Hydraulic Motor Mount
17.	DF1A	Hydraulic Motor (Super 7+4)
*	ST88	Hydraulic Motor (Twin Auger)
18.	DF7	1/2" Close Nipple
19.	DF15	Flow Control Valve
20.	HE58	1/2" Street Elbow
21.	DF17	1/2" x 2" Pipe Nipple
22.	DF8	1/2" Pipe Tee
23.	DF18	1/2" Check Valve
24.	S395	Hydraulic Hose - 10-1/2"
25.	S388	Extra Unit Drive Kit
26.	S412	Drive Kit (complete Super 7+4)
27.	ST90	Drive Kit (complete - Twin Auger)

NOTE: * (Means Not Shown)

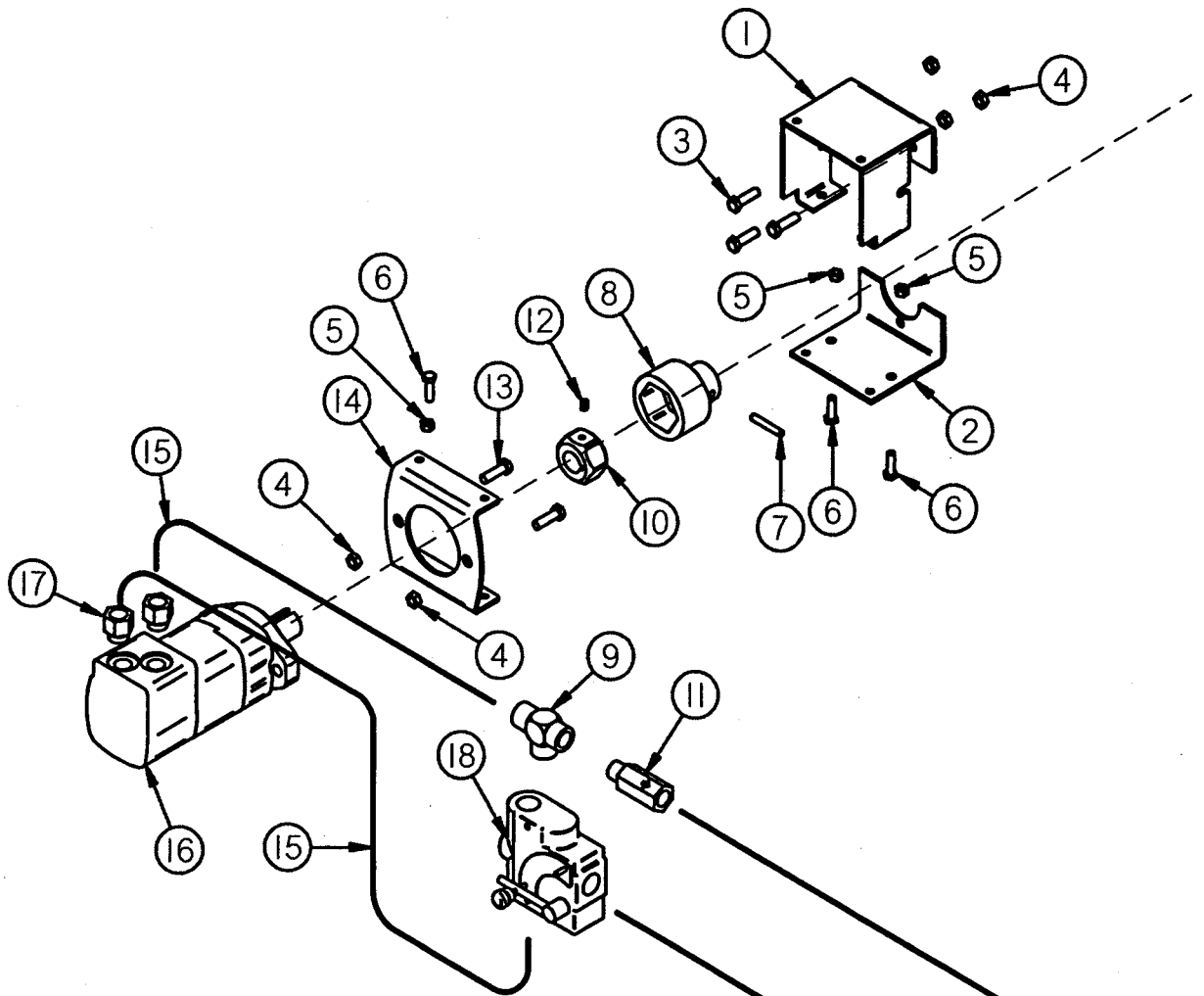

**FIGURE 13
OPTIONAL FRONT HYDRAULIC DRIVE
(2000 SERIES)**

ITEM	PART NO.	DESCRIPTION
1.	S382	Top Motor Hanger
2.	S383	Bottom Motor Hanger
3.	17G141	3/8" x 1-1/4" GR. 5 Bolt
4.	K60	3/8" Nut
5.	T116	5/16" Nut
6.	12V66	5/16" x 3/4" Bolt
7.	3G22	5/16" x 1-3/4" Expansion Pin
8.	S411	Secondary Drive
9.	S460	Male-Female Tee (5604-12)
10.	S463	Primary Drive
11.	PB185	Check Valve
12.	S435	5/16" Set Screw
13.	LW134	3/8" x 1-1/2" GR. 5 Bolt
14.	S464	Hydraulic Motor Mount
15.	S462	Hydraulic Hose 3/4" x 44"
16.	16SV150	Hydraulic Motor (104-1027-006)
17.	S461	O'Ring Adapter
18.	33SV74	Flow Control Valve

INSTRUCTIONS FOR ORDERING PARTS

All service parts should be ordered through your authorized H&S dealer. They will be able to give you faster service if you will provide them with the following

1. Model & Serial number is located in the front center of the box.
2. All reference to left or right apply to the Super Duty as viewed from the rear.
3. Parts should not be ordered from illustration only. Please order by complete part number.
4. If your dealer has to order parts - give shipping instructions:

VIA truck - large pieces (please specify local truck lines)

VIA United Parcel Service (include full address)

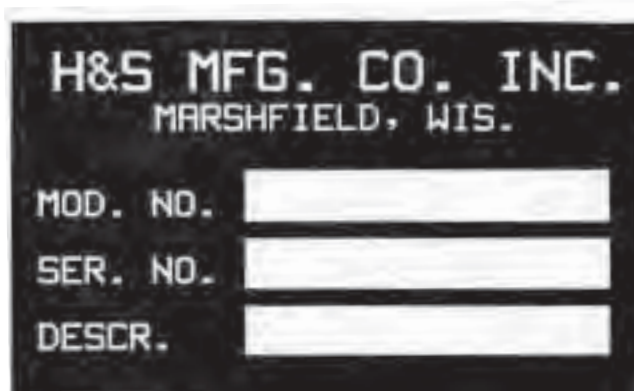

H&S MFG. CO. INC.
MARSHFIELD, WIS.

MOD. NO.

SER. NO.

DESCR.

PLEASE RECORD NUMBERS FOR YOUR UNIT FOR QUICK REFERENCE

ABOUT IMPROVEMENTS

H&S IS CONTINUALLY STRIVING TO IMPROVE IT'S PRODUCTS

We must therefore, reserve the right to make improvements or changes whenever it becomes practical to do so without incurring any obligation to make changes or additions to the equipment previously sold.

H&S MFG. CO.

products approved

for the

FEMA

SEAL OF QUALITY

